

INSTRUCTION MANUAL

AL-346V Centre Lathe (240V) 330 x 1000mm Turning Capacity



L555D

METAL LATHE INSTRUCTION MANUAL

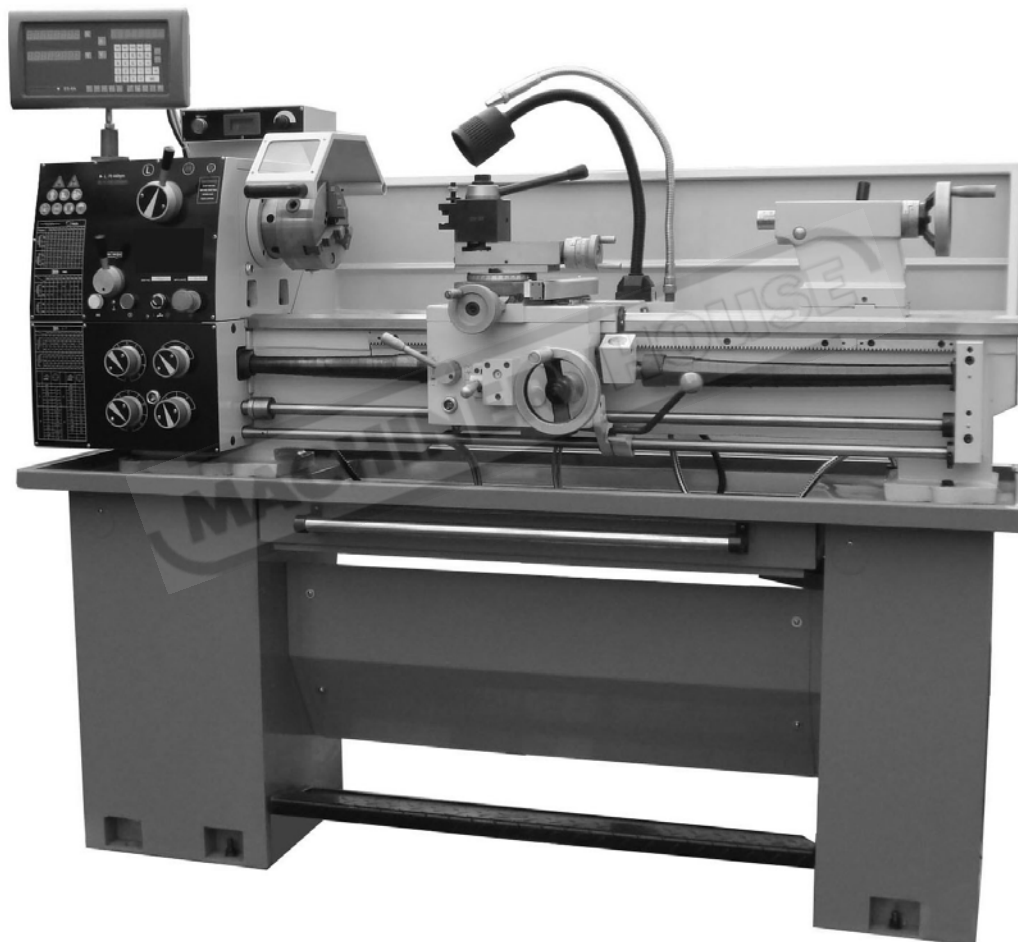

TABLE OF CONTENTS

TABLE OF CONTENTS	1	cutting fluid system	26
INTRODUCTION	2	Steady rest & follow rest	26
SECTION 1: SAFETY	4	Tool post	27
Safety instructions for machinery	4	Spindle speed	28
Additional safety for metal lathes	5	Manual feed	28
Additional chuck safety	6	Power feed	29
SECTION 2: POWER SUPPLY	7	Feed settings	29
Availability	7	Thread settings	30
Full-load current rating	7	SECTION 5: MAINTENANCE	32
Grounding instructions	7	Schedule	32
Extension cords	7	Cleaning	32
SECTION 3: SETUP	8	Ball oiler and change gears lubrication	32
Preparation	8	Oil reservoirs	33
Unpacking	8	V-belt tension	35
Cleanup	8	Cutting fluid system	35
Site considerations	9	SECTION 6: SERVICE	36
Lifting & moving	10	Troubleshooting	36
Mounting	10	Gib adjustments	38
Adding cutting fluid	11	Backlash adjustment	39
Check gearbox oil	11	Half nut adjustment	40
Power connection	11	Feed clutch adjustment	40
Installing V-Belts	12	Tailstock lock	41
Test run	12	Gap insert removal	41
SECTION 4: OPERATION	13	Machine storage	42
Operation overview	13	SECTION 7: PARTS LIST	43-80
Controls	14		
Chuck & faceplate removal	17		
Three-Jaw chuck	19		
Four-Jaw chuck	20		
Faceplate	22		
Centers	23		
Tailstock	24		

INTRODUCTION

Manual accuracy

We are proud to offer this manual with your new machine! We've made every effort to be exact with the instructions, specifications, drawings, and photographs of the machine we used when writing this manual. However, sometimes we still make an occasional mistake.

Also, owing to our policy of continuous improvement, your machine may not exactly match the manual. If you find this to be the case, and the difference between the manual and machine leaves you in doubt, please contact us for help.

Machine description

1. The purpose of a metal lathe is to face, turn, knurl, thread, bore, or cut tapers in a metal work piece with perfect accuracy. **2.** During typical operations, the lathe spindle rotates the work piece at various speeds against a fixed cutting tool that is positioned at a particular angle for the desired type of cut. **3.** The cutting tool is mounted on a tool post, which is positioned by three different slides that each move in different directions. **4.** Opposite of the headstock and spindle is a support device called a tailstock. The tailstock can be slid along the lathe bed and locked in place to firmly support the end of a work piece.

Identification

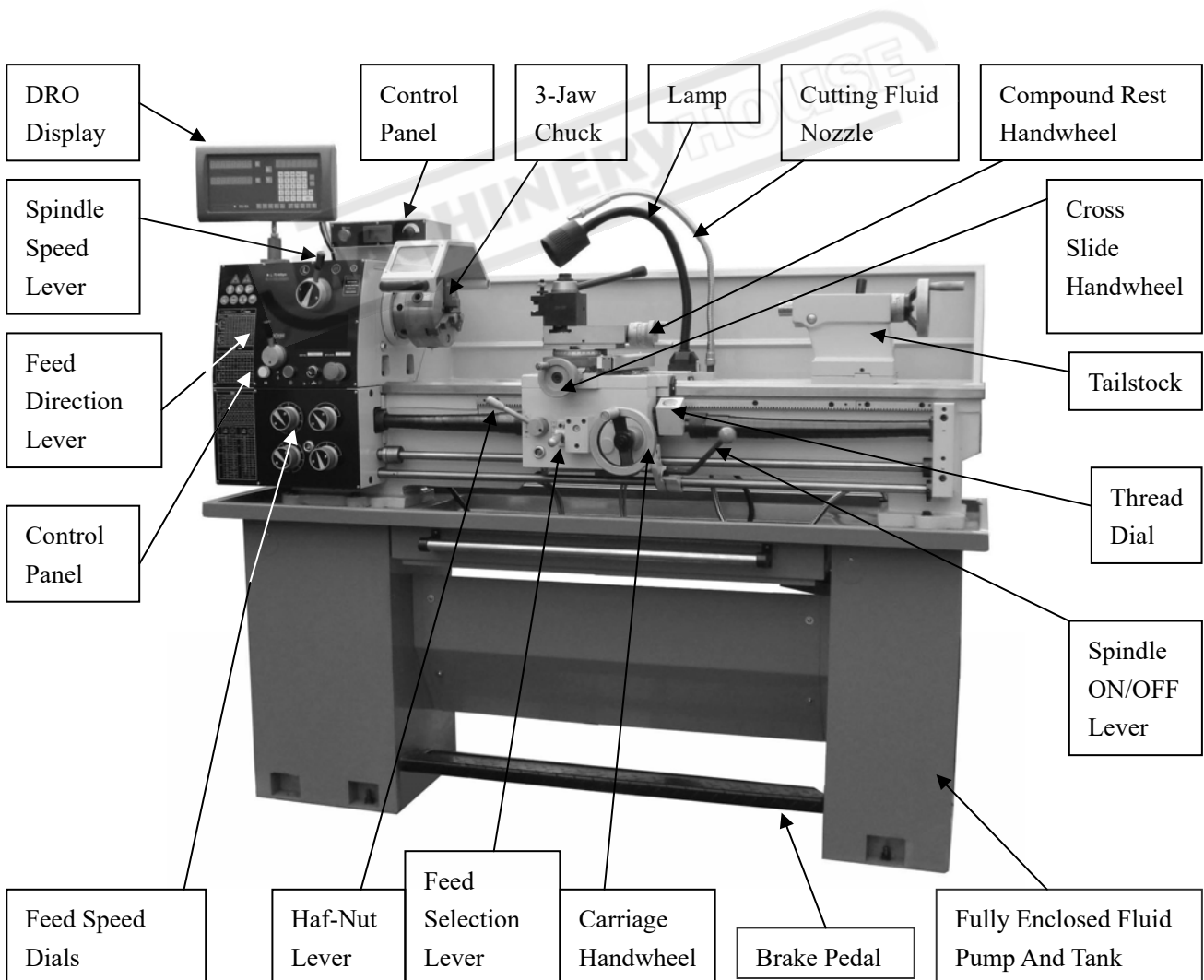

Technical parameter

MAX. Swing over bed-----	330mm (13 ")
MAX. Swing over cross slide-----	198mm (7.8")
MAX. Swing over gap-----	17.71" (450mm)
MAX. Distance between centers-----	1000mm (39.4")
Bed width-----	181mm (7.08")
Spindle bore-----	40mm (1.574")
Cam lock system-----	D4
Spindle taper-----	MT No.5
Spindle speed-----	70-2000rpm/2spets
Top Slide travel-----	75mm (2.95")
Cross slide travel-----	130mm (5.1")
Carriage travel-----	760mm (29.9")
Cross-feed-----	0.013-0.31mm (0.0005"-0.012")
Longitudinal feed-----	0.053-1.29mm (0.002"-0.051")
Range of inch threads-----	4-60 TPI/36 steps
Range of metric threads-----	0.4-7mm/32 steps
Tailstock taper-----	MT No.3
Tailstock barrel travel-----	100mm (4")
Cutting tool (Max. section) -----	14X14mm (0.55"x0.55")
Weight (Net) -----	600kg (1338 Lbs)
Weight (Shipping) -----	635kg (1416 Lbs)
Crate size (LXBXH) -----	1870x740x1565mm (73.62 "X29.13"X61.62")
Motor output-----	1.5kw (2HP)

SECTION 1: SAFETY

For your own safety, read instruction manual before operating this machine

DANGER! Indicates an imminently hazardous situation which, if not avoided, will result in death or serious injury.

WARNING! Indicates a potentially hazardous situation which, if not avoided, could result in death or serious injury.

CAUTION! Indicates a potentially hazardous situation which, if not avoided, may result in minor or moderate injury.

NOTICE! This symbol is used to alert the user to useful information about proper operation of the equipment, and/or a situation that may cause damage to the machinery.

Safety instructions for machinery

WARNING!

1. Owner's manual. Read and understand this owner's manual before using machine.

2. trained operators only. Untrained operators have a higher risk of being hurt or killed. Only allow trained/supervised people to use this machine. When machine is not being used, disconnect power, remove switch keys, or lock-out machine to prevent unauthorized use—especially around children. Make workshop kid proof!

3. Dangerous environments. Do not use machinery in areas that are wet, cluttered, or have poor lighting. Operating machinery in these areas greatly increases the risk of accidents and injury.

4. Mental alertness required. Full mental alertness is required for safe operation of machinery. Never operate under the influence of drugs or alcohol, when tired, or when distracted.

5. Electrical equipment injury risks. You can be shocked, burned, or killed by touching live electrical components or improperly grounded machinery. To reduce this risk, only allow qualified service personnel to do electrical installation or repair work, and always disconnect power before accessing or exposing electrical equipment.

6. Disconnect power first. Always disconnect machine from power supply before making adjustments, changing tooling, or servicing machine. This prevents an injury risk from unintended startup or contact with live electrical components.

7. Eye protection. Always wear approved safety glasses or a face shield when operating or observing machinery to reduce the risk of eye injury or blindness from flying particles. Everyday eyeglasses are not approved safety glasses.

8. Wearing proper apparel. Do not wear loose clothing or jewelry that can become entangled in moving parts. Always tie back or cover long hair. Wear non-slip footwear to avoid accidental slips, which could cause loss of work piece control.

9. Hazardous dust. Dust created while using machinery may cause cancer, long-term respiratory damage. Be aware of dust birth defects, or hazards associated with each work piece material, and always wear an approved respirator to reduce your risk.

10. Hearing protection. Always wear hearing protection when operating or observing loud machinery. Extended exposure to this noise without hearing protection can cause permanent hearing loss.

11. Remove adjusting tools. Tools left on machinery can become dangerous projectiles upon startup. Never leave chuck keys, wrenches, or any other tools on machine. Always verify removal before starting!

12. Use correct tool for the jib. Only use this tool for its intended purpose – do not force it or an attachment to do a jib for which for it was not designed. Never make unapproved modifications-modifying tool or using it differently than intended may result in malfunction or mechanical failure that can lead to personal injury or death!

13. Awkward positions. Keep proper footing and balance at all times when operating machine. Do not overreach! Avoid awkward hand positions that make work piece control difficult or increase the risk of accidental injury.

14. Children & bystanders. Keep children and bystanders at a safe distance from the work area. Stop using machine if they become a distraction.

- 15. Guards & covers.** Guards and covers reduce accidental contact with moving parts or flying debris. Make sure they are properly installed, undamaged, and working correctly.
- 16. Forcing machinery.** Do not force machine. It will do the job safer and better at the rate for which it was designed.
- 17. Never stand on machine.** Serious injury may occur if machine is tipped or if the cutting tool is unintentionally contacted.
- 18. Stable machine.** Unexpected movement during operation greatly increases risk of injury or loss of control. Before starting, verify machine is stable and mobile base (if used) is locked.
- 19. Use recommended accessories.** Consult this owner's manual or the manufacturer for recommended accessories. Using improper accessories will increase the risk of serious injury.
- 20. Unattended operation.** To reduce the risk of accidental injury, turn machine **OFF** and ensure all moving parts completely stop before walking away. Never leave machine running while unattended.
- 21. Maintain with care.** Follow all maintenance instructions and lubrication schedules to keep machine in good working condition. A machine that is improperly maintained could malfunction, leading to serious personal injury or death.
- 22. Check damaged parts.** Regularly inspect machine for any condition that may affect safe operation. Immediately repair or replace damaged or mis-adjusted parts before operating machine.
- 23. Maintain power cords.** When disconnecting cord-connected machines from power, grab and pull the plug—not the cord. Pulling the cord may damage the wires inside. Do not handle cord/plug with wet hands. Avoid cord damage by keeping it away from heated surfaces, high traffic areas, harsh chemicals, and wet/damp locations.
- 24. Experiencing difficulties.** If at any time you experience difficulties performing the intended operation, stop using the machine! Please contact technical support.

Additional safety for metal lathes

WARNING!

- 1. Speed rates.** Operating the lathe at the wrong can cause nearby parts to break or the work piece to come loose, which will result in dangerous projectiles that could cause severe impact injuries. Large or non-concentric work pieces must be turned at slow speeds. Always use the appropriate feed and speed rates.
- 2. Chuck Key safety.** A chuck key left in the chuck can become a deadly projectile when the spindle is started. Always remove the chuck key after using it. Develop a habit of not taking your hand off of a chuck key unless it is away from the chuck.
- 3. Safe clearances.** Work pieces that crash into other components on the lathe may throw dangerous projectiles in all directions, leading to impact injury and damaged equipment. Before starting the spindle, make sure the work piece has adequate clearance by hand-rotating it through its entire range of motion. Also, check the tool and tool post clearance, chuck clearance, and saddle clearance.
- 4. Long stock safety.** Long stock can whip violently if not properly supported, causing serious impact injury and damage to the lathe. reduce this risk by supporting any stock that extends from the chuck/headstock more than three times its own diameter. Always turn long stock at slow speeds.
- 5. Securing Work piece.** An improperly secured work piece can fly off the lathe spindle with deadly force; witch can result in a severe impact injury. Make sure the work piece is properly secured in the chuck or faceplate before starting the lathe.
- 6. Chucks.** Chucks are heavy and difficult to grasp, witch can lead to crushed fingers or hands if mishandled. Get assistance when handing chuck to reduce this risk. protect your hands and the precision-ground ways buy using a chuck cradle or piece of plywood over the ways of the lathe when servicing chucks. Use lifting devices when necessary.
- 7. Clearing chips.** Metal chips can easily cut bare skin—even through a piece of cloth. Avoid clearing chips by hand

or with a rag. Use a brush or vacuum to clear metal chips.

8. Stopping spindle by hand. Stopping the spindle by putting your hand on the work piece or chuck creates an extreme risk of entanglement, impact, crushing, friction, or cutting hazards. Never attempt to slow or stop the lathe spindle with your hand. Allow the spindle to come to a stop on its own or use the brake.

9. Crashes. Aggressively driving the cutting tool or other lathe components into the chuck may cause an explosion of metal fragments, which can result in severe impact injuries and major damage to the lathe. Not leaving lathe unattended, and checking clearances before starting the lathe. Make sure no part of the tool, tool holder, compound rest, cross slide, or carriage will contact the chuck during operation.

10. Coolant safety. Coolant is a very poisonous biohazard that can cause personal injury from skin contact alone. Incorrectly positioned coolant nozzles can splash on the operator or the floor, resulting in an exposure or slipping hazard. To decrease your risk, change coolant regularly and position the nozzle where it will not splash or end up on the floor.

11. Tool selection. Cutting with an incorrect or dull tool increases the risk of accidental injury due to the extra force required for the operation, which increases the risk of breaking or dislodging components that can cause small shards of metal to become dangerous projectiles. Always select the right cutter for the job and make sure it is sharp. A correct, sharp tool decreases strain and provides a better finish.

Additional chuck safety

WARNING!

1. Entanglement. Entanglement with a rotating chuck can lead to death, amputation, broken bones, or other serious injury. Never attempt to slow or stop the lathe chuck by hand, and always roll up long sleeves, tie back long hair, and remove any jewelry or loose apparel before operating.

2. Chuck speed rating. Excessive spindle speeds greatly increase the risk of the work piece or chuck being thrown from the machine with deadly force. Never use spindle speeds faster than the chuck RPM rating or the safe limits of your work piece.

3. Using correct equipment. Many work pieces can only be safely turned in a lathe if additional support equipment, such as a tailstock or steady/follow rest, is used. If the operation is too hazardous to be completed with the lathe or existing equipment, the operator must have enough experience to know when to use a different machine or find a safer way.

4. Trained operators only. Using a chuck incorrect can result in work pieces coming loose at high speeds and striking the operator or bystanders with deadly force. To reduce the risk of this hazard, read and understand this document and seek additional training from an experienced chuck user before using a chuck.

5. Chuck capacity. Avoid exceeding the capacity of the chuck by clamping an oversized work piece. If the work piece is too large to safely clamp with the chuck, use a face plate or a large chuck if possible. Otherwise, the work piece could be thrown from the lathe during operation, resulting in serious impact injury or death.

6. Clamping force. Inadequate clamping force can lead to the work piece being thrown from the chuck and striking the operator or bystanders. Maximum clamping force is achieved when the chuck is properly maintained and lubricated, all jaws are fully engaged with the work piece, and the maximum chuck clamping diameter is not exceeded.

7. Proper maintenance. All chucks must be properly maintained and lubricated to achieve maximum clamping force and withstand the rigors of centrifugal force. To reduce the risk of a thrown work piece, follow all maintenance intervals and instructions in this document.

8. Disconnect power. Serious entanglement or impact injuries could occur if the lathe is started while you are adjusting, servicing, or installing the chuck. Always disconnect the lathe from power before performing these procedures.

SECTION 2: POWER SUPPLY

Availability

Before installing the machine, consider the availability and proximity of the required power supply circuit. If an existing circuit does not meet the requirements for this machine, a new circuit must be installed. To minimize the risk of electrocution, fire, or equipment damage, installation work and electrical wiring must be done by an electrician or qualified service personnel in accordance with all applicable codes and standards.

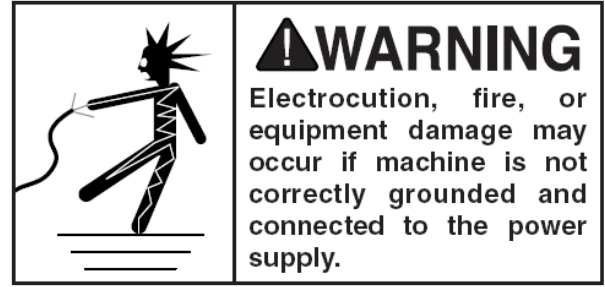

Full-load current rating

The full-load current rating is the amperage a machine draws at 100% of the rated output power. On machines with multiple motors, this is the amperage drawn by the largest motor or sum of all motors and electrical devices that might operate at one time during normal operations.

The full-load current is not the maximum amount of amps that the machine will draw. If the machine is overloaded, it will draw additional amps beyond the full-load rating.

If the machine is overloaded for a sufficient length of time, damage, overheating, or fire may result—especially if connected to an undersized circuit. To reduce the risk of these hazards, avoid overloading the machine during operation and make sure it is connected to a power supply circuit that meets the requirements of the machines.

A power supply circuit includes all electrical equipment between the breaker box or fuse panel in the building and the machine. The power supply circuit used for this machine must be sized to safely handle the full-load current drawn from the machine for an extended period of time.

CAUTION! For your own safety and protection of property, consult an electrician if you are unsure about wiring practices or electrical codes in your area.

Grounding instructions

This machine **MUST** be grounded. In the event of certain malfunctions or breakdowns, grounding reduces the risk of electric shock by providing a path of least resistance for electric current.

WARNING! Serious injury could occur if you connect the machine to power before completing the setup process.

DO NOT connect to power until instructed later in this manual.

Improper connection of the equipment-grounding wire can result in a risk of electric shock. The wire with green insulation and yellow stripes is the equipment-grounding wire. If repair or replacement of the power cord or plug is necessary, do not connect the equipment-grounding wire to a live (current carrying) terminal.

Check with a qualified electrician or service personnel if you do not understand these grounding requirements, or if you are in doubt about whether the tool is properly grounded. If you ever notice that a cord or plug is damaged or worn, disconnect it from power, and immediately replace it with a new one.

Extension cords

We do not recommend using an extension cord with this machine. If you must use an extension cord, only use it if absolutely necessary and only on a temporary basis.

Extension cords cause voltage drop, which may damage electrical components and shorten motor life. Voltage drop increases as the extension cord size gets longer and the gauge size gets smaller (higher gauge numbers indicate smaller sizes). Any extension cord used with this machine must contain a ground wire, match the required plug and receptacle, and wire as short as possible.

SECTION 3: SETUP

Preparation

The list below outlines the basic process of preparing your machine for operation. Specific steps are covered later in this section. The typical preparation process is as follows:

1. Unpack the lathe and inventory the contents of the box/crate.
2. Clean the lathe and its components.
3. Identify an acceptable location for the lathe and move it to that location.
4. Level the lathe and bolt it to the floor.
5. Assemble the loose components and make any necessary adjustments or inspections to ensure the lathe is ready for operation.
6. Check lathe for proper lubrication.
7. Connect the lathe to the power source.
8. Test run lathe to ensure it functions properly.
9. Perform the spindle break-in procedure to prepare the lathe for operation.

Unpacking

Your machine was carefully packaged for safe transportation. Remove the packing materials from around your machine and inspect it. If you discover the machine is damaged, please contact us.



Cleanup

The unpainted surfaces of your machine are coated with a heavy-duty rust preventative that prevents corrosion during shipment and storage. This rust preventative works extremely well, but it will take a little time to clean.

Be patient and do a thorough job cleaning your machine. The time you spend doing this now will give you a better appreciation for the proper care of your machine's unpainted surfaces.

There are many ways to remove this rust preventative, but the following steps work well in a wide variety of situations. Always follow the manufacturer's instructions with any cleaning product you use and make sure you work in a well-ventilated area to minimize exposure to toxic fumes.

Before cleaning, gather the following:

- Disposable Rags
- Cleaner/degreaser
- Safety glasses & disposable gloves
- Plastic paint scraper (optional)

Basic steps for removing rust preventative:

1. Put on safety glasses.
2. Coat the rust preventative with a liberal amount of

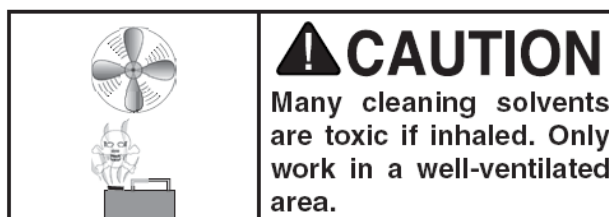
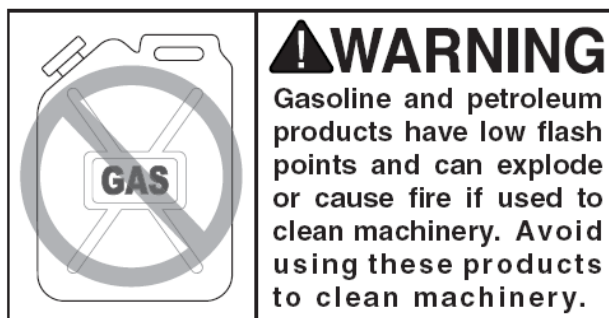

cleaner/degreaser, then let it soak for 5–10 minutes.

3. Wipe off the surfaces. If your cleaner/degreaser is effective, the rust preventative will wipe off easily. If you have a plastic paint scraper, scrape off as much as you can first, then wipe off the rest with the rag.

4. Repeat Steps 2–3 as necessary until clean, then coat all unpainted surfaces with a quality metal protectant to prevent rust.

Additional cleaning tips

- For thorough cleaning, remove the steady rest, tool post, compound slide, and change gears.
- use a stiff brush when cleaning the threads on the leadscrew.
- Move the slides and tailstock back and forth to thoroughly clean/lubricate underneath them.
- After cleaning, wipe down the ways with a high-quality way oil.

NOTICE

Avoid chlorine-based solvents, such as acetone or brake parts cleaner, that may damage painted surfaces.

Site considerations

Weight Load

Refer to the Machine Data Sheet for the weight of your machine. Make sure that the surface upon which the machine is placed will bear the weight of the machine, additional equipment that may be installed on the machine, and the heaviest work piece that will be used. Additionally, consider the weight of the operator and any dynamic loading that may occur when operating the machine.

Space Allocation

Consider the largest size of work piece that will be processed through this machine and provide enough space around the machine for adequate operator material handling or the installation of auxiliary equipment. With permanent installations, leave enough space around the machine to open or remove doors/covers as required by the maintenance and service described in this manual.

CAUTION

Children or untrained people may be seriously injured by this machine. Only install in an access restricted location.

See below for required space allocation.

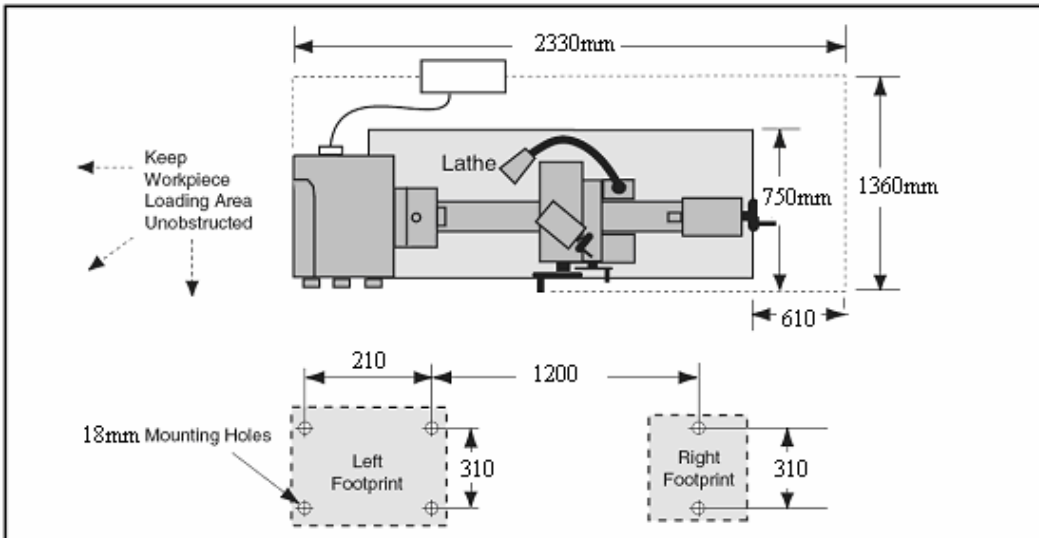

Physical Environment

The physical environment where the machine is operated is important for safe operation and longevity of machine components. For best results, operate this machine in a dry environment that is free from excessive moisture, hazardous chemicals, airborne abrasives, or extreme conditions. Extreme conditions for this type of machinery are

generally those where the ambient temperature range exceeds 41°–104°F (0°–40°C); The relative humidity range exceeds 20–95% (non-condensing); or the environment is subject to vibration, shocks, or bumps.

Electrical Installation

Place this machine near an existing power source. Make sure all power cords are protected from traffic, material handling, moisture, chemicals, or other hazards. Make sure to leave access to a means of disconnecting the power source or engaging a lockout/tagout device, if required.

Lighting

Lighting around the machine must be adequate enough that operations can be performed safely. Shadows, glare, or strobe effects that may distract or impede the operator must be eliminated.

Lifting & moving

WARNING! You must use power lifting equipment and assistance to lift and move this machine. Inspect all lifting equipment to make sure it is in working order and rated for the load before attempting to lift. Ignoring this warning may lead to serious personal injury or death.

This lathe has a hole built into each end of the stand (see figure) that is designed to accept a sturdy 25mm (1") diameter lifting bar. Each bar must extend far enough from the stand so that chains or lifting straps can be looped or connected to all four corners and the lathe can be lifted.

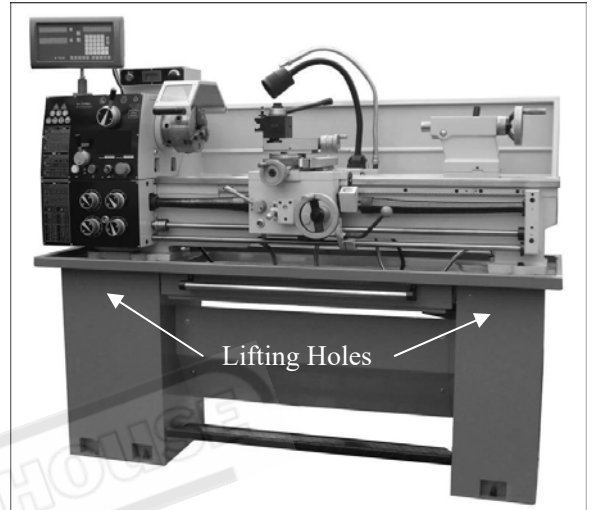

Mounting

Although not required, we recommend that you mount your new machine to the floor. Because this is an optional step and floor materials may vary, floor mounting hardware is not included. Generally, you can either bolt your machine to the floor or mount it on machine mounts. Both options are described below. Whichever option you choose, it is necessary to level your machine with a precision level.

Bolting to concrete floors

Lag shield anchors with lag screw and anchor studs (see figure) are two popular methods for anchoring an object to a concrete floor. We suggest you research the many options and methods for mounting your machine and choose the best that fits your specific application.

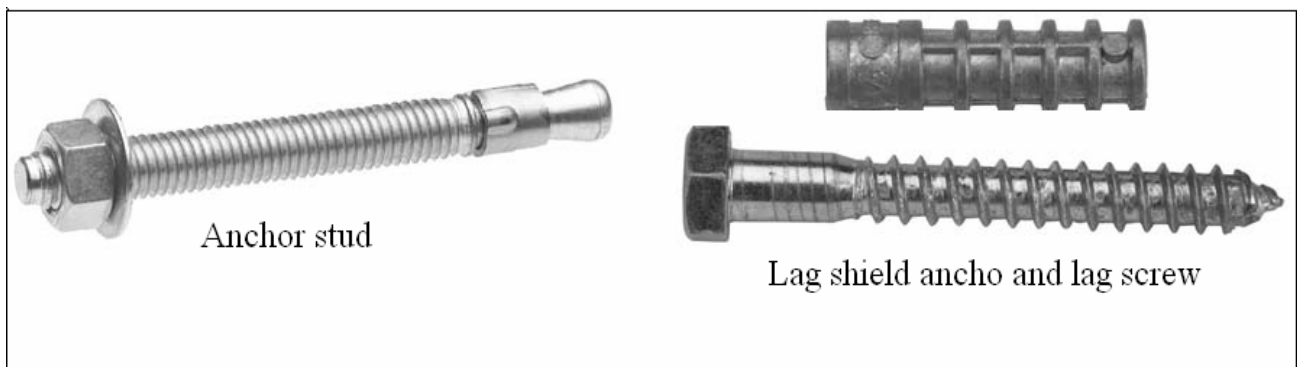

Using machine mounts

Using machine mounts, shown in **Figure**, gives the advantage of fast leveling and vibration reduction. The large size of the foot pads distributes the weight of the machine to reduce strain on the floor.

Using foundation bolts

Place the lathe on a solid foundation. A concrete floor is the best base for the machine. (If necessary, use an under frame operational). Make sure there is sufficient area around the lathe for easy work and maintenance. Use a precision level on the bedways to make further adjustment for level condition, tighten the foundation bolts evenly and finally recheck for level condition.

NOTICE! For accurate turning results and to prevent warping the cast iron bed and ways, the lathe bedways must be leveled from side-to side and from front-to back on both ends. Re-check the bedways 24 hours after installation, two weeks after that, and then annually to make sure they remain level.

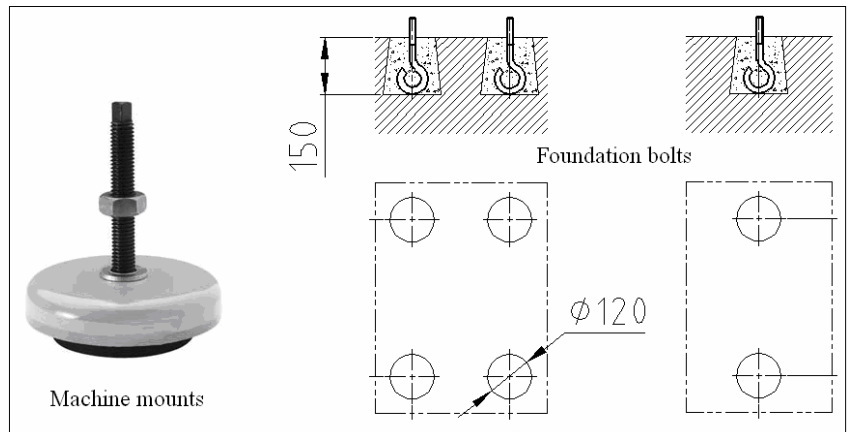

Check gearbox oil

It is critical that there is oil in the headstock, quick change gearbox, and the apron gearbox before proceeding with the test run. Refer to the lubrication instructions on page 32 for more details on which type and how much oil to use in each gearbox.

Adding cutting fluid

For detailed instructions on where the cutting fluid tank is located and how to add fluid, refer to cutting fluid system on page 35.

Power connection

Once all preparation steps previously described in this manual have been completed, the machine can be connected to the power source. In order to be connected to the power source, a circuit must be installed/prepared that meets the requirements of the lathe, and a power connection method must be established for that circuit.

Using an incorrectly sized cord causes machine electrical components and the cord to become very hot, which can lead to component failure or result in fire. For best results, use the shortest length of cord possible, and never use a smaller cord gauge than the specified minimum.

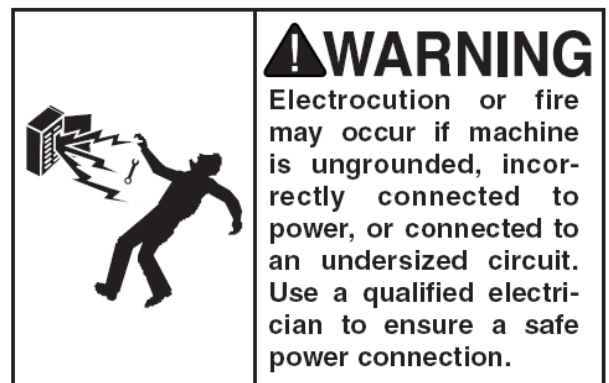

Installing V-Belts

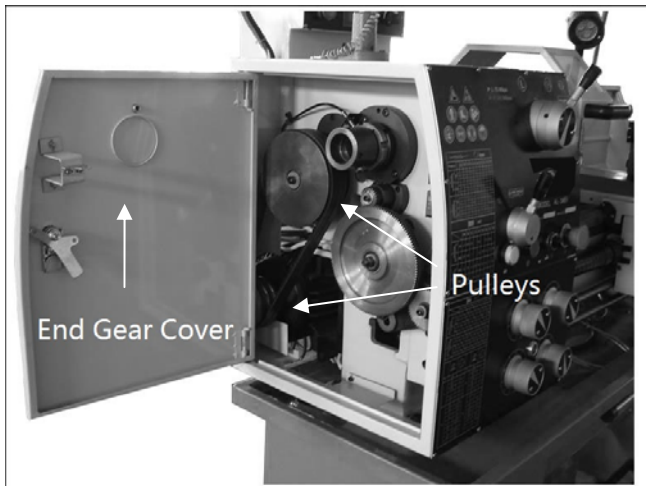

1. Open end gear cover to expose pulleys.
2. Clean surfaces of pulleys, making sure to remove and oily residue from pulley sheaves
3. Install and tension V-belts (refer to Tensioning/Replacing V-Belts on Page 35 in **Owner's Manual** for detailed instructions)
4. Wipe face of pulleys with light layer of way oil to prevent rust. Take care to avoid leaving any excess oil that could get flung off or contact belts.

Test run

Once assembly is complete, test run the machine to make sure it runs properly and is ready for regular operation. The test run consists of verifying the following: the motor powers up and runs correctly and the stop button safety feature works correctly.

If, during the test run, you cannot easily locate the source of an unusual noise or vibration, stop using the machine immediately, then review troubleshooting on page 36. If you cannot find a remedy, contact our tech support for assistance.

To begin the test run:

1. Make sure you understand the safety instructions at the beginning of the manual and that all previous setup sections have been completed.
2. Make sure the lathe is lubricated and the oil levels are at the full mark. Refer to maintenance on page 32 for details.
3. Make sure the chuck is correctly secured to the spindle. Refer to chuck and faceplate mounting on page for detailed installation instructions.
4. Make sure all tools and objects used during setup are cleared away from the machine.

NOTICE! Never shift lathe gears when lathe is operating, and make sure both the half nut lever and the feed selection lever are disengaged before you start the lathe! Otherwise the carriage may feed into the chuck or tailstock and cause severe damage.

5. Disengage the half-nut lever and the feed selection lever (see **Figure 1**), and make sure the saddle lock is loosened to allow the lead screw or feed rod to move the apron if required.

6. Make sure the cutting fluid pump switch is OFF; point the cutting fluid nozzle into the lathe chip pan.

WARNING! Before starting the lathe, make sure you have performed any preceding assembly and adjustment instructions, and you have read through the rest of the manual and are familiar with the various functions and safety features on this machine. Failure to follow this warning could result in serious personal injury or even death!

7. Rotate the stop button (see **Figure 2**) clockwise until it pops out..

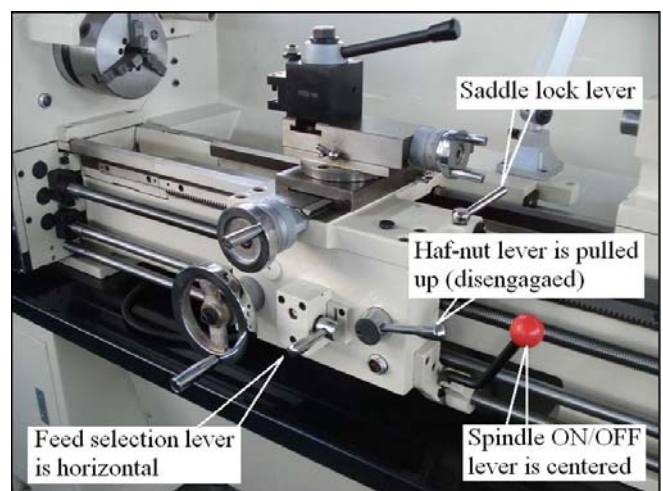

Figure 1

8. Move the feed direction lever (**see Figure 2**) to the disengaged middle position.
9. Turn the spindle speed control knob (**Figure 2**) all the way counterclockwise (lowest speed) to avoid possibility of a high-speed start.
10. Move the spindle speed range lever (**Figure 2**) to the “L” position so the headstock is set in the low range (70-440RPM). You may need to slightly rotate the chuck by hand to engage the lever.
11. Connect the lathe to power source, and then turn the main power switch to the **ON** position (**Figure 3**)
12. Move the spindle ON/OFF lever to start the lathe. The spindle will rotate at 70 rpm. When operating correctly, the machine runs smoothly with little or no vibration or rubbing noises.
 - investigate and correct strange or unusual noises or vibrations before operating the machine further. Always disconnect the machine from power when investigating or correcting potential problems.

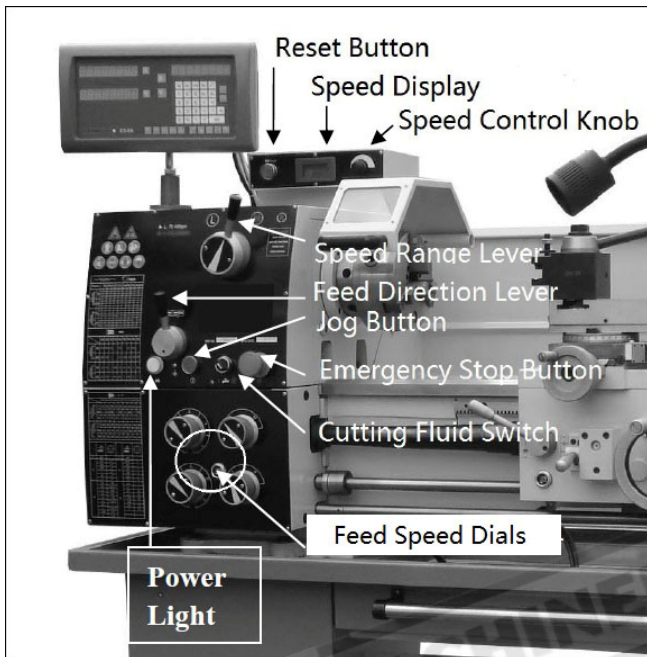

Figure 2

13. Move the spindle ON/OFF lever to the center position, and press the stop button.
14. Without resetting the stop button, move the spindle ON/OFF lever down. The machine should not start.
 - if the machine does not start, the stop button safety feature is working correctly. Continue to the next step.
 - if the machine starts (with the stop button pushed in), immediately disconnect power to the machine. The stop button safety feature is not working correctly. This safety feature must work properly before proceeding with regular operations. Call tech support for help.
15. Rotate the stop button clockwise until it pops out.
16. Make sure the lamp works.
17. Make sure that the cutting fluid nozzle is pointing toward the chip pan, then turn the cutting fluid pump switch and open the nozzle valve. After verifying that cutting fluid flows from the nozzle, turn the cutting fluid switch OFF.
18. Start the spindle, and then step on the brake pedal. The power to the motor should be cut and the spindle should come to an immediate stop.

SECTION 4: OPERATION

Operation overview

This overview is the basic process that occurs when operating this machine. Familiarize yourself with these steps to better understand the remaining parts of the operation section.

To complete a typical operation, the operator does the following:

1. Puts on safety glasses, rolls up sleeves, removes jewelry, and secures any clothing, jewelry, or hair that could get entangled in moving parts.

2. Examines the work piece to make sure it is suitable for turning, and then mounts the work piece required for the operation.
3. Mounts the tooling, aligns it with the work piece, and then adjusts it for a safe startup clearance.
4. Clears all tools from the lathe.
5. Sets the correct spindle speed for the operation.
6. Checks for safe clearances by rotating the work piece by hand one full revolution.
7. Moves slides to where they will be used during operation. If using power feed, selects the proper feed rate for the operation.
8. Turns the main power switch ON, resets the stop button so it pops out, then moves the spindle ON/OFF lever to start spindle rotation. The spindle will rotate forward (the top of the chuck rotates toward the operator).
9. Uses the carriage handwheels or power feed options to move the tooling into the work piece for operations.
10. When finished cutting, moves the ON/OFF lever to the center position to turn the lathe OFF then removes the work piece.

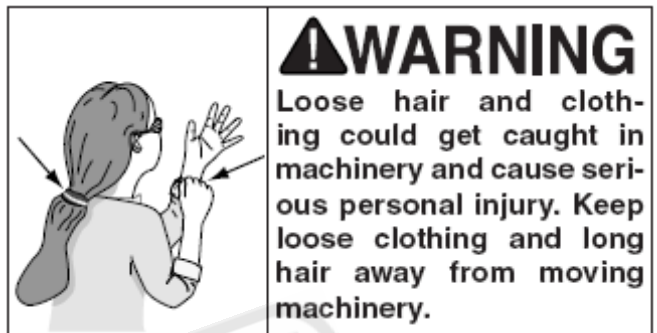

Controls

Main Power Switch

The main power switch is shown in **Figure 3**. It turns master power ON/OFF to the lathe.

Headstock controls

Use the descriptions in this section and the controls shown in **Figure 2** to quickly understand the functions of the headstock and quick change gearbox controls, and to find their locations on the lathe.

01. Spindle Speed Range Levers: Shifts the headstock into low or high range for spindle speeds between 70-440 RPM or 350-2000 RPM.



Figure 3

02. Feed Direction Lever: Controls the forward and reverse direction of the carriage and cross feed. When this lever moved left or right, the direction of the quick change gearbox, feed rod, and lead screw reverse direction, but spindle direction is unaffected.

03. Power Light: When the lathe is connected to power, it is not necessarily ready for use. Only when the stop button is twisted clockwise and popped-out, and the on button has been pushed will the power light illuminate and indicate that all electrical controls are "live" and ready for use. Just because the power light is OFF, do not assume that the

lathe is safe for electrical work, general adjustments, or work piece changes. You must always disconnect the lathe from power before attempting any of these tasks.

04. Cutting fluid ON/OFF Switch: Toggles the cutting fluid pump ON or OFF. Never turn the cutting fluid pump on and let it run while the reservoir is empty, or pump damage may occur.

05. Feed Speed Dials: Engage either the feed rod or leadscrew, and set the apron speed for threading, turning, or facing operations.

06. Emergency Stop Button: Cuts power to the spindle motor and the control panel. No braking occurs and the spindle, chuck, and work piece wind-down naturally. After being pressed, the stop button stays pushed in until it is reset by twisting the knob clockwise until it pops back out.

07. Jog Button: Bumps the motor ON and OFF so partial spindle rotation occurs in reverse. Useful when the lathe is stopped in low range and the lathe gear reduction makes it difficult for the machinist to rotate the chuck by hand in order to reposition a chuck or work piece. **Note:** In order to use the jog button, the Spindle ON/OFF lever must be in the central or OFF position.

08. Speed Display: Displays the current spindle speed in RPM.

09. Speed Control Knob: Changes the spindle speed within the set speed range.

10. Reset Button: Motor will stop when the load exceeds the motor rated power and the red light of the Reset Button will be lighted. If you want to restart the lathe, first move the Spindle ON/OFF Lever to the STOP position, then push the Reset Button and the red lights will be gone out. Now you can restart the lathe.

Apron controls

Use the descriptions in this section and the controls shown in **Figure 4** to quickly understand the functions of the apron and its related controls.

Spindle ON/OFF Lever

Starts and stops the spindle in forward and reverse.

- Moving the lever upward from the central OFF position spins the chuck forward (the top of the chuck moves toward the machinist).
- Moving the lever downward from the central position spins the chuck in reverse (the top of the chuck moves away from the machinist).

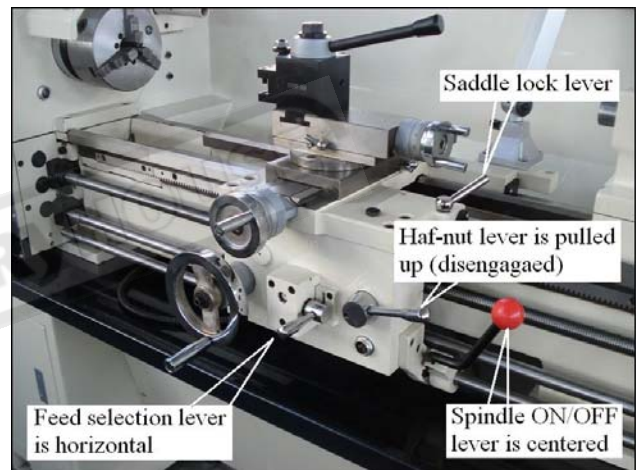

Figure 4

Feed Selection Lever: Allows the machinist to engage or disengage the apron for longitudinal or cross feeding tasks.

Carriage Lock Lever: Clamps the right front of the saddle to the lathe way for increased rigidity when facing a workpiece.

Half-Nut Lever: Clamps the halfnut to the leadscrew for threading operations.

Thread Dial: Avoids cross-cutting threads by indicating to the machinist where to re-clamp the half nut in order to resume threading after a carriage return. (**Figure 5**)

Carriage Handwheel

For moves the carriage longitudinally left or right along the ways. (**Figure 5**)

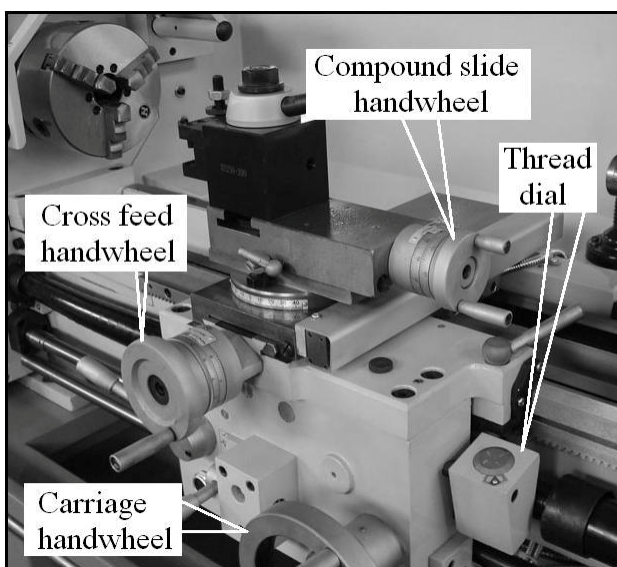

Figure 5

Cross Slide Handwheel

Moves the cross slide in or out perpendicular to carriage travel and is equipped with a standard Dial. (Figure 5)

Compound Slide Handwheel (Figure 5)

Moves the compound and cutting tool relative to the workpiece at various angles with fine-depth control.

Compound Slide Scale (Figure 5)

The 90° rosette on the top of the compound indicates compound angles. Zero splits the scale into two ranges, 45° to the right and 45° to the left in 1° degree increments.

Tailstock

Use the descriptions in this section and the controls shown in Figure 6 to quickly understand the functions of the tailstock controls.

Quill Lock Lever

Secures the quill in a locked or pre-loaded position.

Tailstock Lock Lever

Clamps the tailstock in place for general position locking along the lathe bed.

Set screw

Allows the tailstock to be locked in place using a wrench to control amount of drawdown alignment with the spindle centerline.

Tailstock Handwheel

Advances or retracts the quill in the tailstock at a 1:1 ratio with the micrometer scale on the handwheel hub.

Micrometer Scale

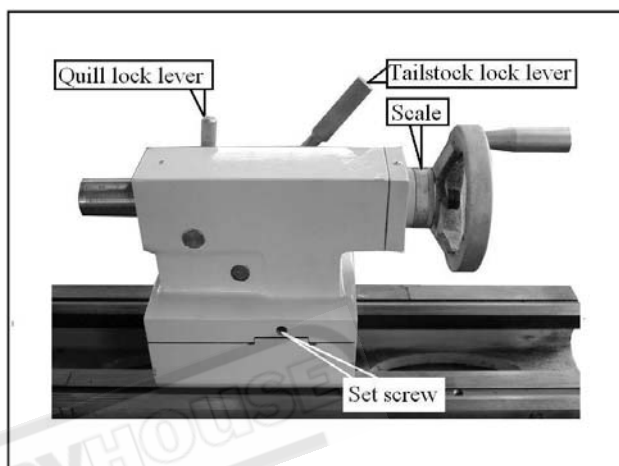

Figure 6

Brake

This lathe is equipped with a foot brake (see Figure7) to quickly stop the spindle. Pushing the foot brake while the spindle is ON cuts power to the motor and stops the spindle. Once stopped, the spindle ON/OFF lever MUST be returned to the neutral position before the spindle can be restarted.

WARNING!

Using the foot brake to stop the lathe reduces risk of an entanglement injury from allowing the lathe to coast to a stop. Use the foot brake to stop the lathe whenever possible.

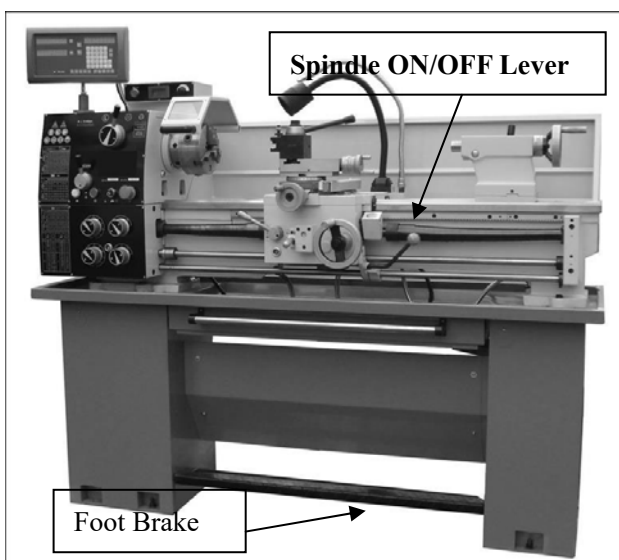

Figure 7

Chuck & faceplate removal/installation

This lathe is shipped with a 3-jaw chuck installed, but some time you need to use a 4-jaw chuck or faceplate. The chucks and faceplate mount to the spindle with a camlock system, which uses a key to loosen and tighten camlocks for removal or installation (see Figure 8).

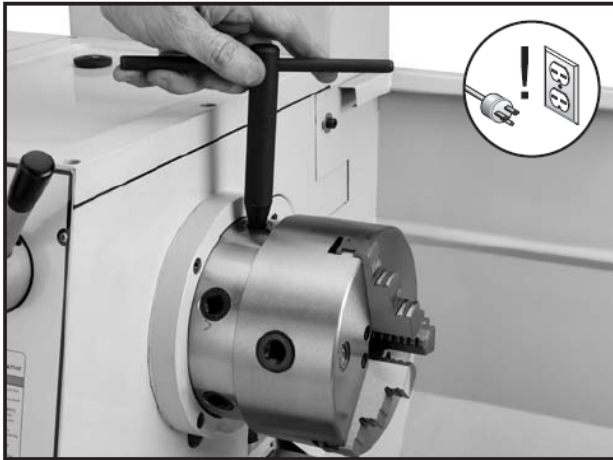

Figure 8

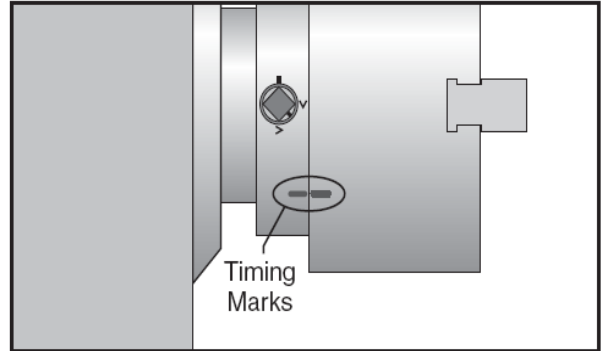

Figure 9

Before the 4-jaw chuck and faceplate can be installed on the spindle, their respective cam studs must be installed and adjusted. To maintain consistent removal and installation of the chucks and faceplate, each should have a timing mark that can be lined up with a matching one on the spindle, so it will be installed in the same position every time (see Figure 9). Before removing the 3-jaw chuck, verify that a timing mark exists. If a mark cannot be found, stamp your own on both the chuck and spindle.

Chuck & faceplate removal

1. Disconnect lathe from power!
2. Lay a chuck cradle (see Figure 10) or a layer of plywood over the bed ways to protect the precision ground surfaces from damage and to prevent fingers from being pinched.

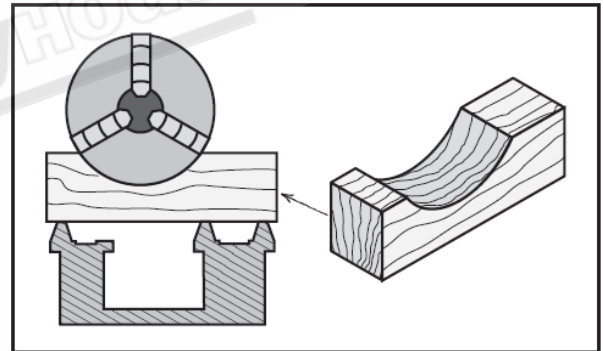

Figure 10

⚠ WARNING

PINCH HAZARD! Protect your hands and the precision ground bedways with plywood or a chuck cradle when removing the lathe chuck! The heavy weight of a falling chuck can cause serious injury.

3. Loosen the cam-locks by turning the key counterclockwise approximately one-third of a turn until the mark on the cam-lock aligns with the single mark on the spindle nose in Figure 11. If the cam-lock stud does not freely release from the cam-lock, wiggle the cam-lock until the cam-lock stud releases. Note: These cam-locks may be very tight. A breaker bar may be used to add leverage.
4. Using a dead blow hammer or other soft mallet, lightly tap around the outer circumference of the chuck body to break the chuck free from the cam-locks and from the spindle nose taper.

Caution: the chuck may come off at this point, so it is important you are ready to support its weight.

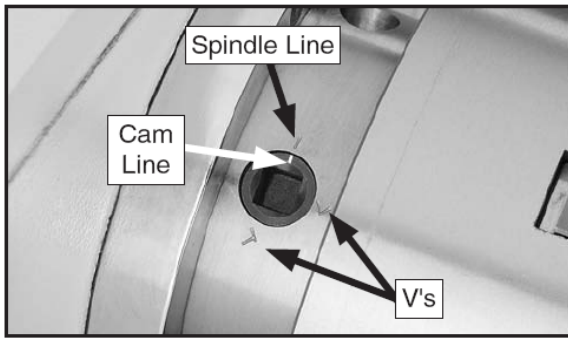

Figure 11

WARNING! Large chucks are very heavy. Always get assistance when removing or installing large chucks to prevent personal injury or damage to the chuck or lathe.

5. Use a rocking motion to carefully remove the chuck from the spindle (**see Figure 12**).

—if the chuck does not immediately come off, rotate the spindle approximately 60° and tap again. Make sure all the marks on the cams and spindle are in proper alignment.

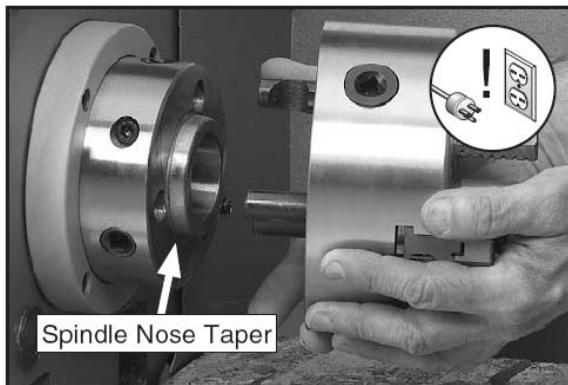

Figure 12

Chuck & faceplate installation

1. Disconnect lathe Form power!
2. Place a piece of plywood across the lathe ways just under the chuck, and use a chuck cradle if desired.
3. Make sure the chuck taper and spindle taper mating surfaces are perfectly clean.
4. Inspect and make sure that all camlock studs are undamaged, are clean and lightly oiled, and that the camlock stud cap screws are in place and snug.

NOTICE! Never install a chuck or faceplate without having the camlock cap screws in place or fully tightened. If you ignore this notice, once installed the chuck may never be able to be removed since the camlock studs will turn with the camlocks and never release.

5. Align the chuck-to-spindle timing marks , and slide the chuck onto the spindle.

6. Turn a camlock with the chuck wrench until the cam mark falls between the "v" marks as shown in **Figure 13**.

— If the cam lock mark stops outside of the "v" marks, remove the chuck and adjust the cam stud height of the offending studs one full turn up or down (**see Figure 13**).



Figure 13

7. Lock the other cams in a star pattern so the chuck is drawn up evenly on all sides without any chance of misalignment.

Note: If any of the cam lock marks (**see Figure 14**) do not fall between the "V" marks when the cam lock is tight, you must adjust the offending camlock stud as discussed in Camlock Stud Installation.

8. Remove the chuck wrench.

Camlock stud installation

1. Oil and thread each cam stud into the chuck until the alignment groove is flush with the chuck surface as shown in **Figure 14**. 2. Install and tighten the locking cap screw for each stud, making sure that the camlock studs can slightly rotate back and forth. 3. Place the chuck onto the spindle and tighten the cam locks in an alternating manner to avoid cocking the chuck on the spindle. When tightened:

— If the cam lock mark stops outside of the "v" marks, remove the chuck and adjust the cam stud height of the offending studs one full turn (**see Figure 14**).

— If the final position of each cam mark is between the two "v" marks as shown in **Figure 14**, no stud adjustment is required.

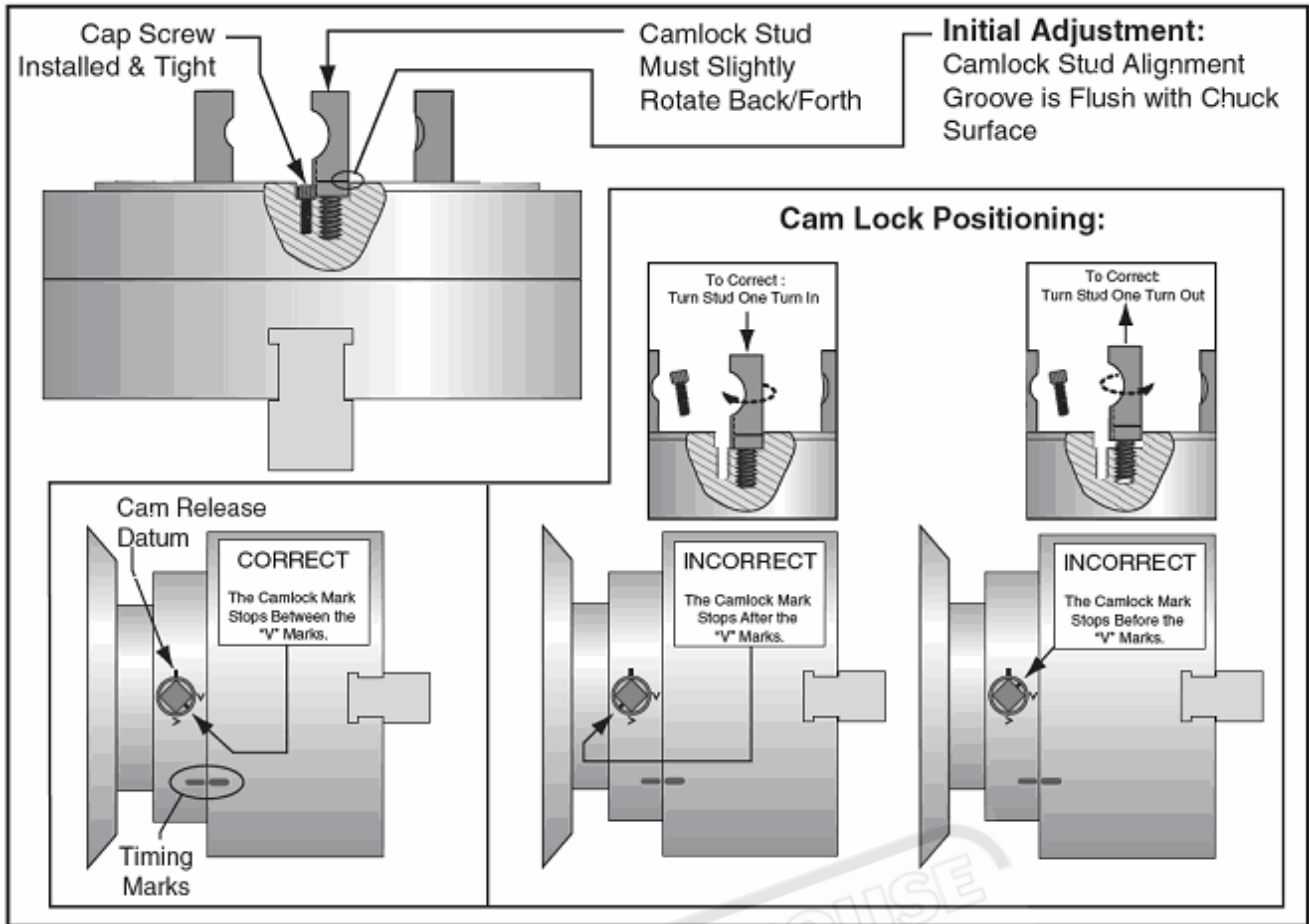

Figure 14

Three-Jaw chuck

This section outlines basic operation safety related to using the 3-jaw chuck included with your lathe. Use knowledge of safety and common sense when applying the steps on how to use this chuck. If you have any questions, feel free to contact our technical support department.

The 3-jaw chuck included with your lathe is a scrolling-type chuck, which means all three jaws move equally when the chuck key is turned. This jaw configuration is used to hold concentric workpieces that are centered with equal pressure from all three jaws.

There is also a reverse set of jaws included with your lathe that accommodate additional workpiece configurations (see Figure 15), both sets of jaws can hold a workpiece on inside or outside surface of the jaw. No matter how you configure the jaws, make sure the workpiece is firmly secured to the chuck.

Mounting workpiece

1. Disconnect the lathe from power.
2. Lay a piece of plywood on the bedway underneath the spindle to protect the precision ground surfaces.
3. Insert the chuck key into a scroll keyway and rotate it counterclockwise to open the jaws until the workpiece sits flat against the chuck face, evenly on the jaw steps, or fits into the chuck hole and through the spindle bore.
4. Close the jaws until they make light contact with the workpiece.
5. Turn the chuck by hand to make sure the workpiece is evenly held by all three jaws and is centered on the chuck.

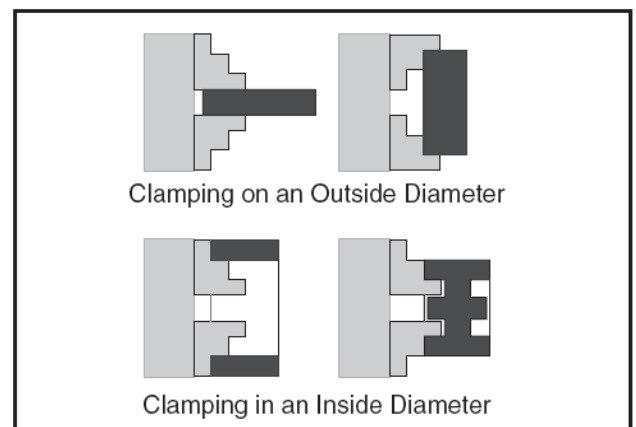

Figure 15

If the workpiece is not centered, loosen the jaws and adjust the workpiece, then re-tighten the jaws and repeat **step 5**. If the workpiece is centered, fully tighten the jaws.

Removing jaws

1. Disconnect the lathe from power.
2. Place a piece of plywood on the bedway to protect it, then remove the chuck from the lathe.
3. Lay the chuck on a flat, stable surface, then insert the chuck key into a scroll keyway and rotate it counterclockwise to back the jaws all the way out of the jaw guides.
4. Thoroughly clean the jaws with shop rags and mineral spirits, then apply a thin coat of an anti-rust protective lubricant before storing them in a protected location free from moisture and abrasives.

Installing jaws

1. Place the chuck on a flat, stable surface.
2. Examine the side of the jaws—each is stamped with a number 1 through 3. Examine the jaw guides of the chuck—each is stamped with a corresponding number (see **Figure 16**).

Note: the jaws and jaw guides are machined to match and each jaw must be installed in its corresponding jaw guide.

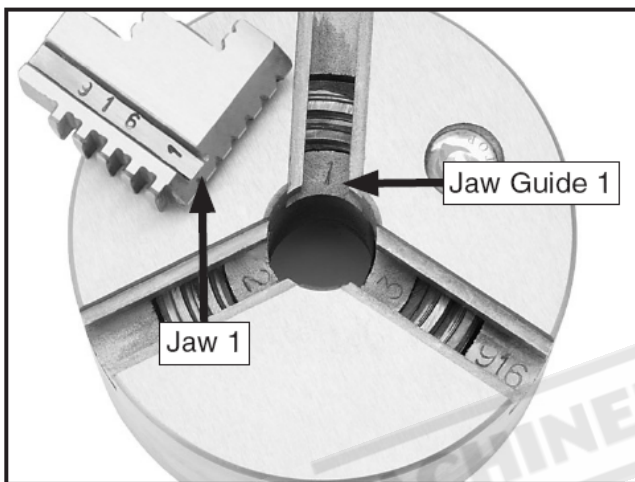

Figure 16

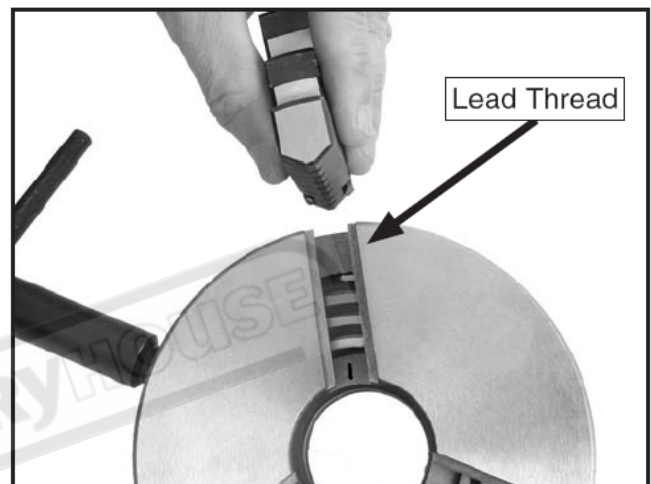

Figure 17

3. Insert the chuck key into a scroll keyway and rotate it until you see the beginning of the scroll gear's lead thread come into view through the #1 jaw guide, then back it off slightly until it disappears (see **Figure 17**).

4. Slide the #1 jaw into the #1 jaw guide and hold it firmly against the scroll gear threads, then rotate the chuck key clockwise approximately one turn until the lead thread engages with the jaw.

Note: Tug on the jaw to make sure it is engaged with the scroll gear thread.

5. Repeat Steps 3-4 for jaws #2 and #3 in sequence.

6. Rotate the chuck key clockwise to bring the jaws together in the center of the chuck.

If installed correctly, the jaws will converge evenly at the center of the chuck.

If the jaws do not come together evenly, remove them, make sure the numbers of the jaws and the jaw guides match, then properly re-install them.

Four-Jaw chuck

This section outlines basic operation safety related to using the 4-jaw chuck included with your lathe. Use knowledge of safety and common sense when applying the steps on how to use this chuck.

Select this chuck for low-speed lathe operations only. The 4-Jaw chuck uses independently adjustable jaws, meaning each is adjusted by an individual worm gear. Non-cylindrical parts can be held and brought into the spindle centerline for facing or boring. The other benefit is that the majority of a workpiece can be positioned out of the spindle rotation axis if a bore or step needs to be cut into a workpiece on an outlying edge.

For the best grip possible on odd-shaped workpieces, one or more jaws can also be rotated 180° to grab more surface

area for clamping.

If all four jaws cannot be used to hold the workpiece, you must use the faceplate for improved clamping options. Otherwise, a severe out-of-balance condition will be created. If spun even at an average speed, this chuck will almost always be out of balance, and the machinist and bystanders will be at risk of being hit with a thrown workpiece. Being hit by an ejected workpiece can be fatal.

Reversing Jaw positions & clamping a Workpiece

Shown in **Figure 18** is an example of the independent jaws holding a non-cylindrical workpiece for off-center boring. One or more jaws can be reversed in any combination to get the best grip on the workpiece.

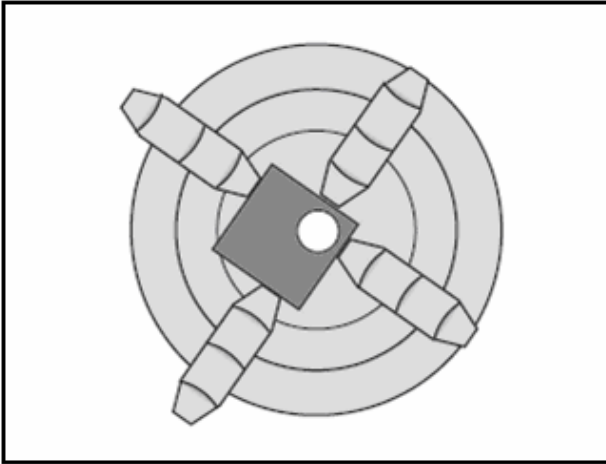

Figure 18

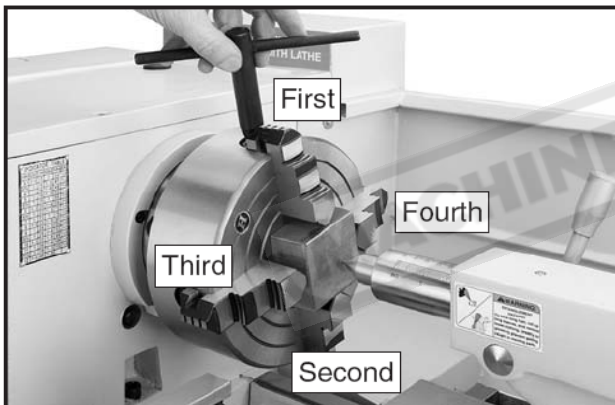

Figure 19

8. After the workpiece is held in place, back the tailstock away and rotate the chuck by hand. the center point will move if the workpiece is out of center (**see Figure 20**).

9. Make fine adjustments by slightly loosening one jaw and tightening the opposing jaw until the workpiece is held securely and precisely aligned with the spindle centerline.

To use the 4-jaw chuck:

1. Disconnect lathe from power!
2. Install a center in the tailstock.
3. Open each jaw with the chuck wrench and place the workpiece flat against the chuck face.
4. Support the workpiece and slide the tailstock forward so the tip of the dead center presses against the workpiece. Next, lock the tailstock in position.
5. Turn the tailstock quill so the dead center applies enough pressure to the center point of your workpiece to hold it in place (**see Figure 19**), then lock the tailstock quill.
6. Turn each jaw until it just makes contact with the workpiece.
7. Tighten each jaw in small increments. After adjusting the first jaw, continue tightening in opposing sequence (**see Figure 19**). Check frequently to make sure the required point on the workpiece has not wandered away from the spindle centerline due to applying too much pressure to a single jaw.

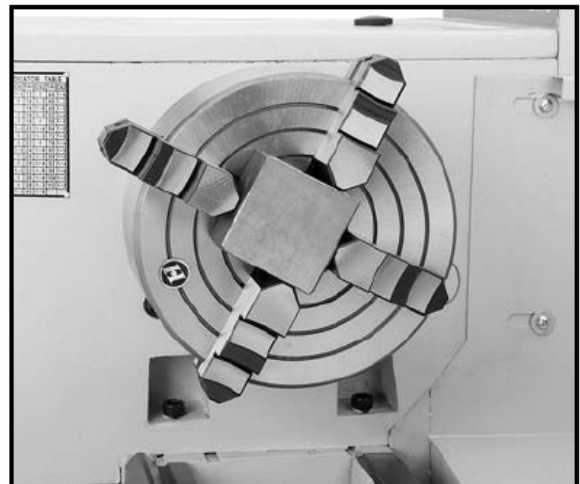

Figure 20

Faceplate

This section outlines basic operation safety related to using the faceplate included with your lathe. Use knowledge of safety and common sense when applying the steps on how to use this faceplate.

The faceplate is cast-iron and has multiple slots for T-bolts that hold clamping hardware. If you suspect that any of the chuck or jaw combinations may not hold a workpiece safely, remove the chuck and install the faceplate as outlined for special clamping options.

However, just as with the 4-Jaw chuck, not all workpieces can be safely held. Holding a workpiece off center or holding an irregular shaped workpiece will cause the entire assembly to rotate out of balance. If spun at any speed higher than low, the workpiece can eject hitting the lathe operator or bystanders causing a severe or fatal injury.

Figure 21 shows an example of a workpiece being improperly held with the 4-jaw chuck. One jaw of the chuck interfered with the workpiece edge, and removing the jaw creates an extreme workpiece ejection hazard. The workpiece holding solution shown in **figure 21** is to use the faceplate with a minimum of three clamps that are spaced as equally apart as possible for full support.

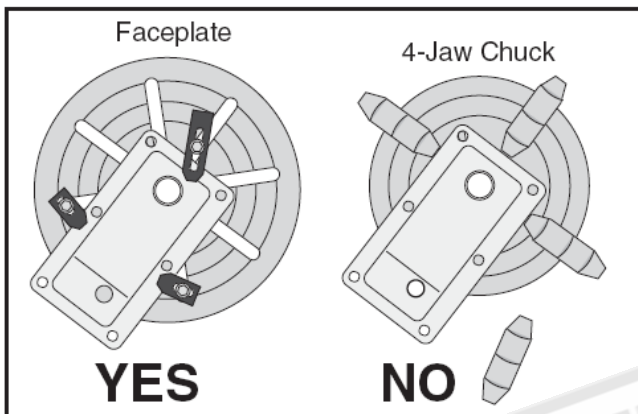

Figure 21

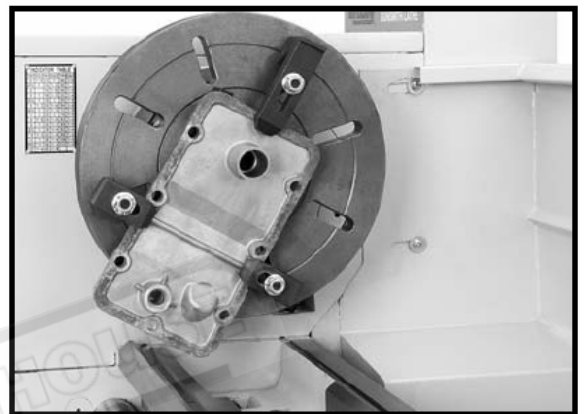

Figure 22

To use the faceplate:

1. Disconnect lathe from power!
2. Insert a dead center into the tailstock, slide the tailstock up to the faceplate, and lock the tailstock into position.
3. Place the workpiece against the faceplate and turn the tailstock quill so the point of the dead center touches and applies enough pressure to hold the workpiece in place.
4. Lock the quill when sufficient pressure is applied to hold the workpiece. Additional support may be needed, depending on the workpiece.
5. Clamp the workpiece at a minimum of three locations that are as close to being evenly spaced apart as possible as shown in Figure 23.

WARNING! Use a minimum of three independent clamping devices when using faceplate. Failure to provide adequate clamping may cause workpiece to eject during operation.

6. Double check for safety and rotation clearance.
7. Slide the tailstock away from the workpiece and install the required tailstock tooling for drilling or boring, or position the tool bit for facing.

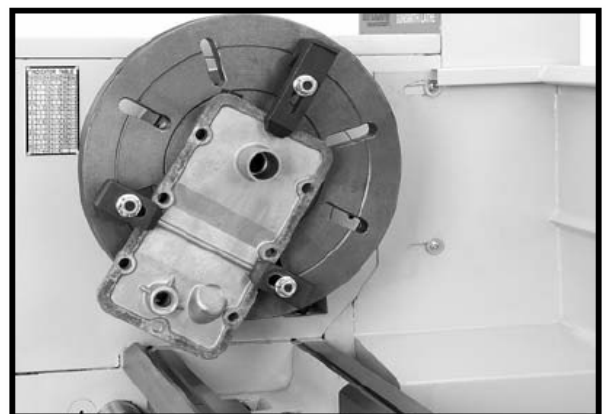

Figure 23

Centers

Some time you need to use dead centers, live center, and adapter sleeve (see **Figure 24**) to adapt the centers into spindle bore. When installing centers verify that all mating surfaces are clean and free of nicks and burrs.

Tip: Hand-held tapered bore wipers make this task very time efficient, and offer consistently clean bores.

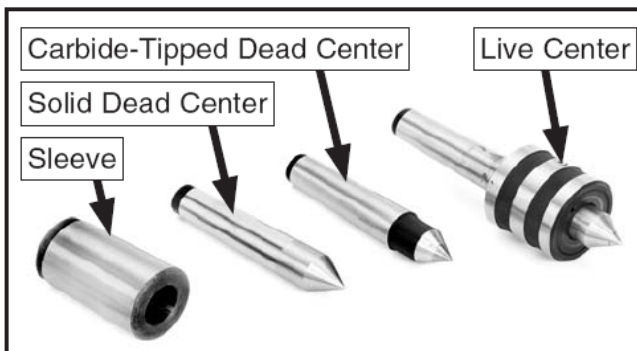

Figure 24

Tip: If the tail is too large for a slot, install the 3-jaw chuck, open the jaws so the workpiece can be supported by the center and the tail of the dog can rest against a jaw.

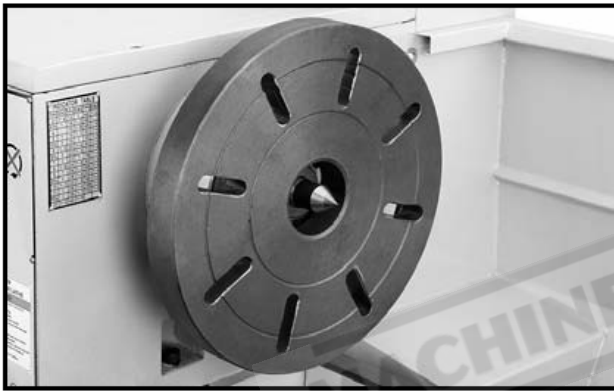

Figure 25

Solid dead center

Dead centers are typically used in low speed turning operations to increase rigidity for close tolerances. The solid dead center is installed at the spindle end of the lathe because the workpiece, center, and spindle all turn together by the use of a lathe dog. One end of the lathe dog is clamped to the workpiece, and the other end the tail, is inserted into a faceplate slot shown in **Figure 25**.

Carbide-tipped dead center

When the workpiece is supported at the tailstock end of the lathe, the workpiece will spin on the tip of the fixed center. To eliminate the tip of the center from wearing out at this point of contact, the carbide-tipped center is used. Nevertheless, during turning operations this tip must still be lubricated vigilantly, or the workpiece will wear, resulting in increased end play and poor turning results. Typically, when using centers, the tailstock quill should be locked and protrude, but not too long.

Live center

If the workpiece must be spun at higher speeds, the live center is inserted into the tailstock. Unlike a dead center, the tip of the live center is supported with precision bearings that allow it to support and spin with the workpiece. As a result, virtually no wear occurs, and the workpiece can be turned with less concern about developing end play from tip wear. However, when using live centers, accuracy can suffer as a result of having bearings support the end of the workpiece.

Installing center in tailstock

1. Center drills the end of the workpiece to be turned or threaded.
2. Feed the quill out about 25mm (1"), wipe clean and insert the center into the quill bore (see **Figure 26**). To help prevent wear, place a dab of grease on the point of the center.
3. Position the tailstock so the center presses against the workpiece, then lock the tailstock in place.
4. Preload the quill into the workpiece. The force against the workpiece will fully seat the tapered center.
5. Lock the quill into place. However, keep in mind that the quill may need to be adjusted during operation to remove any play that develops between the center and the workpiece.

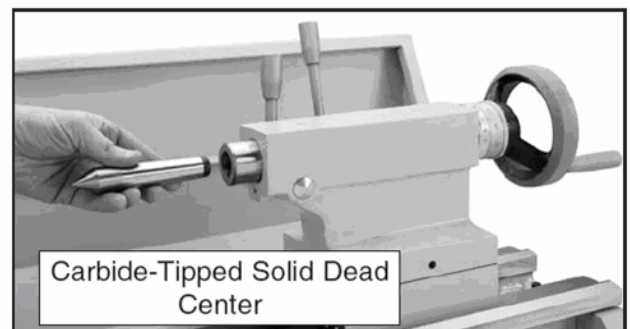

Figure 26

Removing center from tailstock

To remove a center, hold the end of the center with a rag to prevent it from falling, and reverse the handwheel until the center is pressed free.

Installing center in spindle

1. Install the dead center into the spindle sleeve.
2. Install the sleeve into the spindle bore.
3. Determine whether to use the chuck or faceplate, and install the required unit.
4. Clamp the required lathe dog onto the workpiece and mount the workpiece between the lathe centers.

Removing center from spindle

To remove a center and sleeve, hold the end of the center with a rag to prevent it from falling, insert a wooden rod into the outboard side of the spindle, and tap the center and sleeve free.

Tailstock

Offsetting tailstock

By offsetting the tailstock, the dead center can hold a workpiece at a particular away from the spindle centerline so tapers and pipe threads can be cut. For a quick visual tool in keeping track of tailstock movement, an offset scale (see figure 37) with arbitrary increments is located at the rear of the tailstock. However, to achieve exact taper angles, or to adjust the tailstock back into the spindle centerline, angle gauges and a test indicator must be used.

To offset the tailstock:

1. Loosen the tailstock lock lever.
2. using a hex wrench loosen one of the front or rear adjustment screws shown in **Figure 27**.
 - To move the tailstock toward the rear of the lathe, loosen the front adjustment screw and tighten the rear screw.
 - To move the tailstock toward the front of the lathe, loosen the rear adjustment screw and tighten the front screw.
3. Apply the tailstock lock lever, and check the amount of the tailstock offset. Unlock and readjust as required for fine tuning.

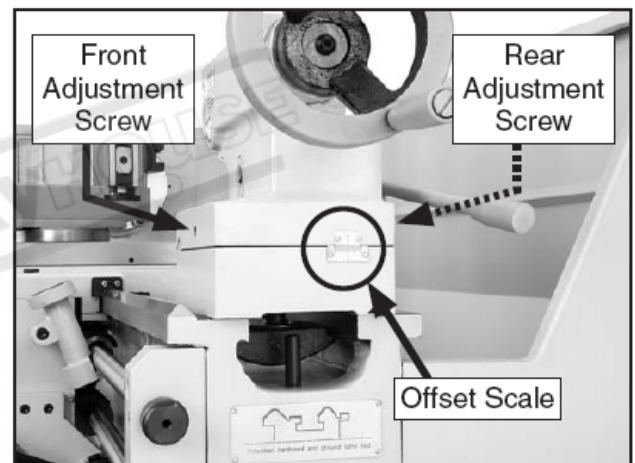

Figure 27

Aligning tailstock

The tailstock alignment was set at the factory with the headstock. However, we recommend that you take the time to ensure that the tailstock is aligned to your own desired tolerances. To align the tailstock:

1. Center drill a 6" long piece of bar stock on both ends. Set it aside for use in **Step 4**.
2. Make a dead center by turning a shoulder to make a shank. Flip the piece over in the chuck and turn a 60° point (see **Figure 28**). As long as it remains in the chuck, the point of your center will be accurate to the spindle axis.

Note: Keep in mind that the point will have to be refinished whenever it is removed and returned to the chuck.

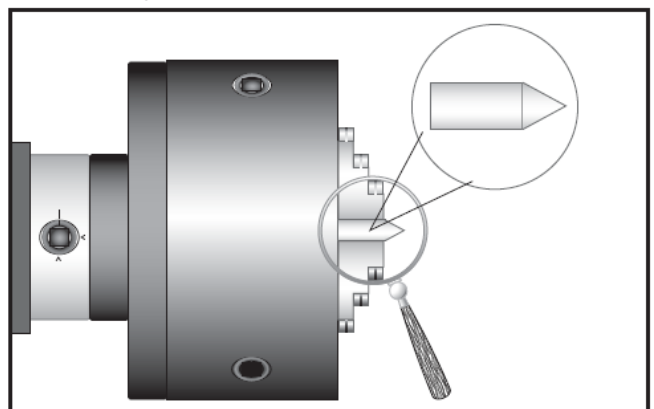

Figure 28

3. Place the live center in your tailstock.
 4. Attach a lathe dog at the spindle end to the bar stock from step 1, and mount it between the centers as shown in **Figure 29**.

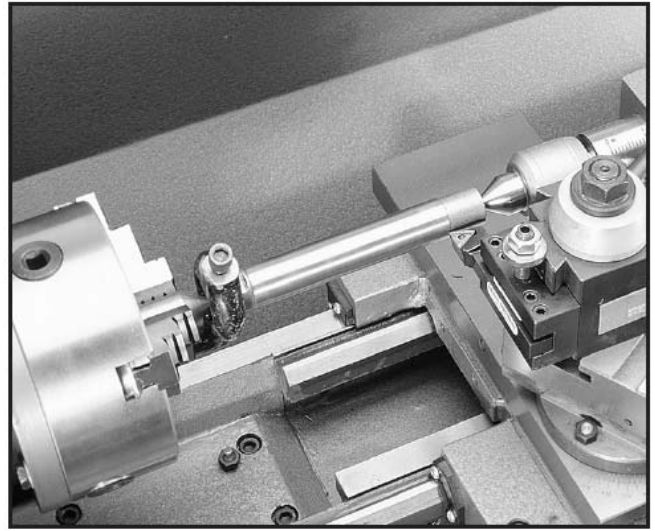

Figure 29

5. Turn approximately 0.25mm (0.010") off the diameter.
 6. Mount a dial indicator so that the plunger is on the tailstock quill (see **Figure 30**).
 7. Measure the stock with a micrometer. If the stock is wider at the tailstock end, the tailstock needs to be moved toward the front of the lathe the amount of the taper (see **Figure 30**).

— If the stock is thinner at the tailstock end, the tailstock needs to be moved toward the rear of the lathe by at least the amount of the taper (see **Figure 31**).

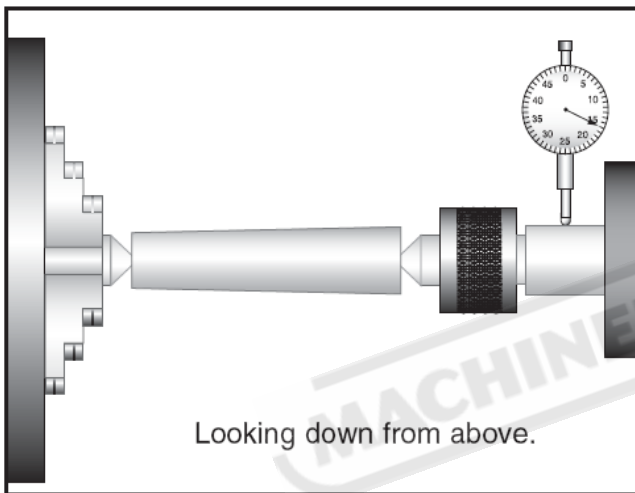

Figure 30

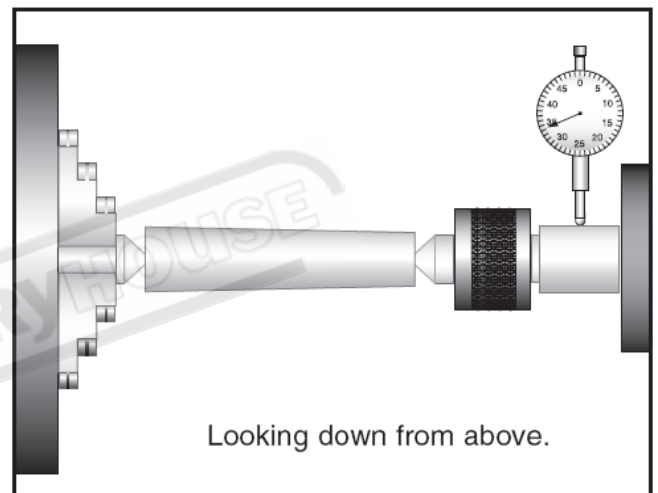

Figure 31

NOTICE! Do not forget to lock the tailstock to the ways after each adjustment.

8. Loosen the tailstock lock lever and adjust the tailstock offset by the amount of the taper.
 9. Turn another 0.25mm (0.010") off of the stock and check for any taper.
 10. Repeat as necessary until the desired level of accuracy is achieved.

Drilling with tailstock

The tailstock quill has an Mt#3 taper with a lock slot at the bottom to accept tang-style tooling. If the tooling will experience high torque loads during operation, it is critical to use tanged-style to prevent the drill bit or arbor from spinning and galling the quill bore. Restoring a galled bore and taper can be time consuming or require quill replacement.

However, tooling without tang-styled arbors can be used if they meet the following criteria.

- Very little torque loads will be applied to the tooling such as with centers.
- The tap or drill bit is not larger than 12.5mm (1/2") in diameter.
- The end of the arbor is solid, or has a screw threaded into the hole making the end of the arbor solid. Installing an arbor with a solid end is important to avoid the arbor from becoming stuck in the quill. Some arbors equipped with the hole are too short to be exposed in the drift slot for removal, and the tailstock pin has no surface to push against when using the handwheel to remove the arbor. As a result, the arbor becomes stuck requiring the quill to be removed and the arbor driven out with a punch.

Tip: When drilling or when tapping operations need to be done deep into a part, the quill can also be stabilized by slightly applying the lever to add drag and preload to the quill.

To install a tapered drill or chuck:

1. Lock the tailstock in position, then unlock the quill.
2. Use the quill feed handwheel to extend the quill about 25mm (1") out of the tailstock.

3. Insert an Mt#3 chuck arbor or drill bit into the quill just until the tang drops into the slot and the tapers just touch.

Tip: For maximum locking of large diameter drill bits, push and seat the drill bit into the quill with a clockwise rotation as to load the tang against its slot.

4. Tap the end of the tooling or drill bit with a wooden block or mallet to seat the tool.
5. Lock the quill.

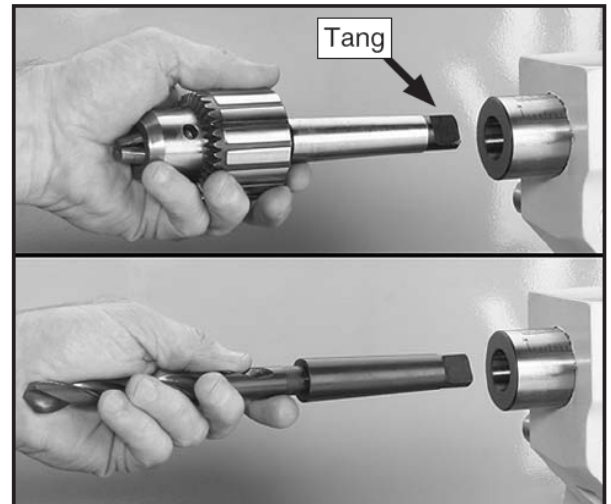

Figure 32

To remove a tapered drill or chuck:

Turn the handwheel counterclockwise until the arbor or drill bit is pushed out from the tailstock taper.

—if the tool is stuck in the bore and cannot be removed by turning the handwheel with moderate force, extend the quill to expose the drift key slot, and use any standard drift key to remove the stuck tooling.

Cutting fluid system

The cutting fluid system delivers cutting fluid via a flexible distribution hose and nozzle. The cutting fluid pump turns ON and OFF with a switch located on the control panel. Fluid flow is controlled by a manual flow control valve (see Figure 33).

NOTICE! Running the pump without adequate cutting fluid in the reservoir may permanently damage it. This type of damage is not covered by the warranty.

Always use high quality cutting fluid and follow the manufacturer's instructions for diluting. Frequently check the cutting fluid condition and change it promptly when it becomes overly dirty or rancid.

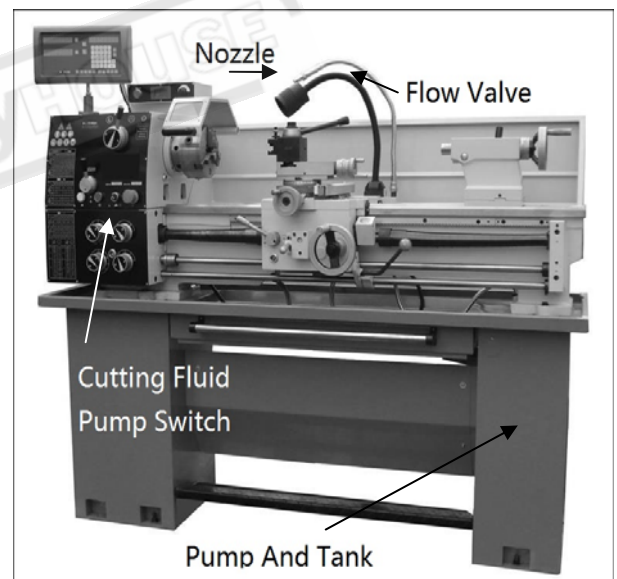

Figure 33

To use the cutting fluid system:

1. Make sure the cutting fluid tank is properly serviced and filled.
2. Position the cutting fluid nozzle as desired for your operation.
3. Use the control panel switch to turn the cutting fluid pump **ON**.
4. Adjust the flow of cutting fluid by using the flow valve.

Steady rest & follow rest

Selecting and using rests

To minimize deflection, in workpieces like rods, dowels, tubes, and small diameter solid shafts, the steady rest or follow rest is used.

The steady rest is clamped to the ways and supports the workpiece with three fingers at a single point between the chuck and the tailstock.

The follow rest is bolted to the carriage and travels with it during turning or threading operations. Two fingers support the workpiece while the tool tip acts as the third support during cutting.

Both the steady rest and the follow rest use solid brass tips. The fingers have a guide slot where the tip of an adjustable set screw rides. These screws are held in place with jam nuts. The set screws must be tightened inward far enough so they bottom slightly, providing preload and keeping the finger in alignment with only slight rocking in its bore.

When using either of these rests, keep in mind that most machining operations must be done at low spindle speeds to prevent a workpiece ejection hazard.

To install the rests:

1. Disconnect lathe from power!
2. Select the required rest (**see Figure 34**) for the operation, and wipe all mounting surfaces clean with a lightly oiled rag.
 - to install the steady rest, place it on the lathe bed where workpiece support is needed. Engage the base clamp with the way underside and tighten the mounting nut with a wrench.
 - to install the follow rest, fasten the base to the saddle with two provided cap screws using a hex wrench.
3. Install the workpiece and support it at both ends.
4. Without causing deflection, adjust the fingers until the solid brass tips just touch the workpiece.
5. Lock the fingers in place with the set screws and jam nuts.

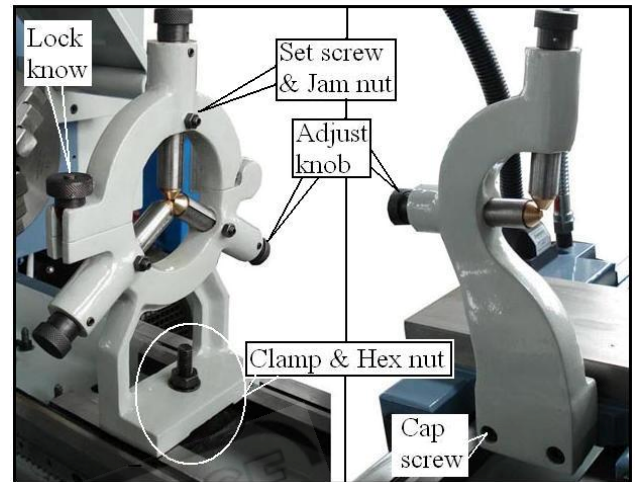

Figure 34

Tool post

The included tool post is a 250 series piston-type quick-change model. The quick-change lock lever allows for one or more tool holders to be quickly loaded and unloaded in two available dovetailed slots. By having extra tool holders and setting the tool height in advance, swapping between tooling is efficient for production-sensitive schedules. When loosened, the mounting hex nut allows the entire tool post to rotate 360° for angle adjustments.

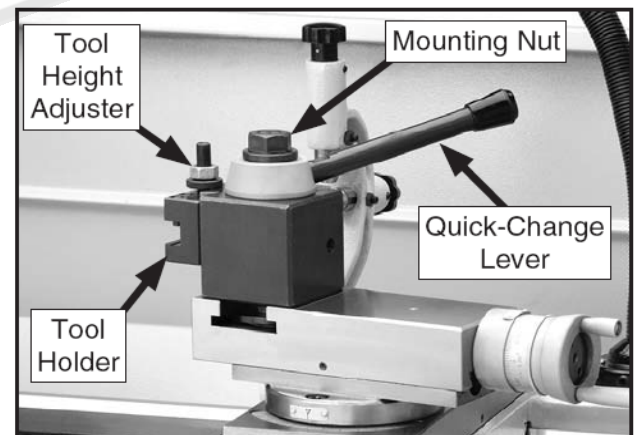

Figure 35

To load a tool holder:

1. Install the required cutting tool in the tool holder.
2. Move the quick-change lever (**see Figure 35**) to recess the lock piston and provide an unobstructed slot for the tool holder to slide down into.
3. Slide the tool holder into position, and tighten the quick-change lever.
4. Use the handwheels to bring the tool to the required position.
5. Double check that tool angle, height, and position are correct.
6. Make sure that all fasteners related to the tool, holder, and tool post are tight.

Spindle speed

Using the correct spindle speed is important for safe and satisfactory results, as well as maximizing tool life.

To set the spindle speed for your operation, you will need to:

(1) Determine the best spindle speed for the cutting task, and (2) configure the lathe controls to produce the required spindle speed.

To change the spindle speed:

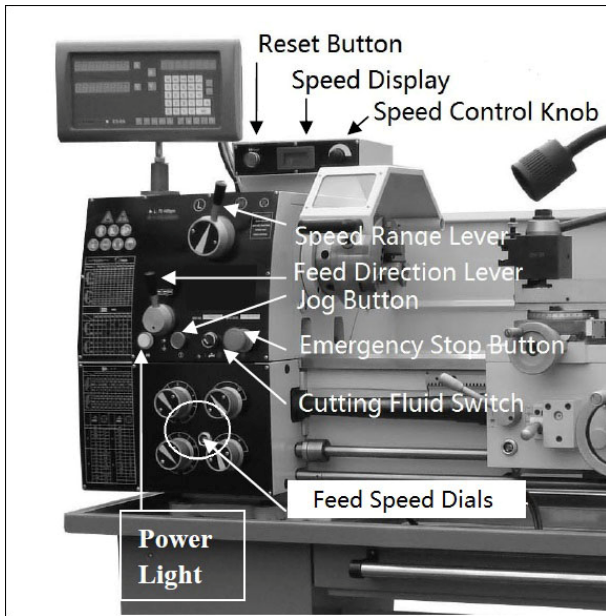

1. Make sure the spindle is turned OFF and it has come to complete stop.

2. Move the spindle speed range lever to the range that covers your calculated spindle speed. When the lever to the L position, the speed range is 70-440 RPM, when the lever to the H position, the speed range is 350-2000 RPM.

Note: To shift the spindle speed range lever, you may need to apply pressure to the lever and slightly rotate the spindle by hand.

Warning!

Make sure the variable speed control knob is turned all the way to the left (counterclockwise) before turning the lathe ON, or it may start up at a dangerously high rate of speed.

Figure 36

4. Turn the spindle ON and slowly turn the variable speed control knob to carefully adjust the spindle speed (show on the spindle speed display) to your calculated spindle speed.

Manual feed

You can manually move the cutting tool around the lathe for facing or turning operations using the handwheels shown in **Figure 37**.

Carriage handwheel: For moves the carriage longitudinally left or right along the ways.

Cross slide handwheel: For moves the cross slide in or out perpendicular to carriage travel.

Compound slide handwheel: For moves the compound and cutting tool relative to the workpiece at various angles.

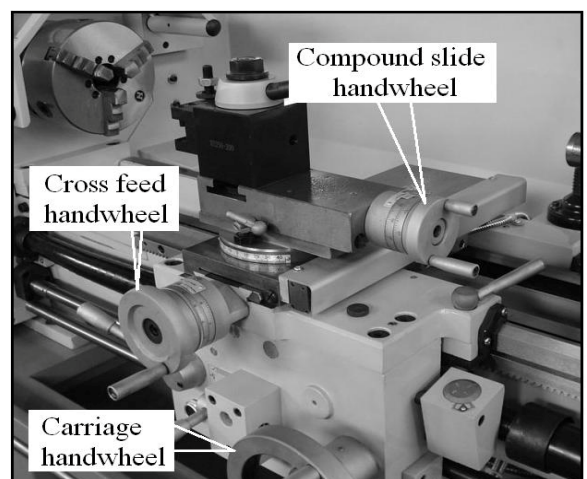

Figure 37

Power feed

The feed selection lever (see **Figure 38**) allows the machinist to engage or disengage the apron for longitudinal or cross feeding tasks.

Sometimes it is necessary to rock the carriage handwheel or the cross feed handwheel to assist in fully engaging the chosen feed gears. To prevent inadvertent apron damage, the apron is equipped with an internal lockout system that prevents the feed selection lever and half-nut levers from being engaged at the same time. However, before engaging the apron for any longitudinal feed operations, make sure that the carriage lock is loose and the carriage is allowed to move freely, or the feed system may be damaged.

Moving the feed selection lever upwards from the central or disengaged position engages the cross slide for in-and-out facing operations.

Moving the feed selection lever downwards from the central disengaged position, engages the carriage for left-or-right longitudinal turning operations.

The speed at which the carriage travels is set with the feed speed dials, the feed direction is changed by the feed direction lever on the headstock..

NOTICE! A high feed rate or threading at a high speed reduces your reaction time to disengage the apron or leadscrew to avoid a crash with the spinning chuck. When threading, making too deep of a cut can result in the half nut binding with the leadscrew causing an impaired ability to disengage the half nut to avoid a chuck crash. pay close attention to the feed rate you have chosen and keep your foot poised over the brake pedal. Failure to fully understand this may cause the carriage to crash into the chuck.

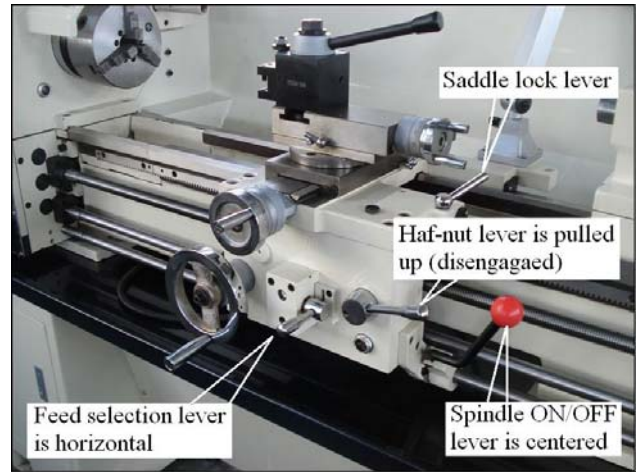

Figure 38

Feed settings

Various feed rates are achieved on this lathe by moving knobs, levers, and rearranging change gears according to the threading chart located on the headstock..

To set up for a power feed operation:

1. Disconnect lathe from power!
2. Open the change gear's door on the left-hand side of the headstock to expose the change gears.

3. look at the lathe feed rate chart, and find the required feed rate for your turning or facing operation. See **Figure 39**, some numbers are carriage feed, and some numbers are cross feed. If for example, a carriage feed rate of 0.083mm is needed, the change gears and feed dials must be in the following positions:

		⊘ / mm									
Position		B5	B4	C4	C3	C2	A4	D2	E4	A2	E2
 SI	↖	0.053	0.073	0.083	0.092	0.104	0.11	0.115	0.129	0.138	0.16
	↘	0.013	0.018	0.02	0.022	0.025	0.026	0.028	0.03	0.033	0.038
 SII	↖	0.105	0.15	0.165	0.184	0.207	0.221	0.23	0.258	0.276	0.32
	↘	0.025	0.035	0.04	0.044	0.05	0.053	0.055	0.06	0.066	0.076
 SI	↖	0.21	0.29	0.33	0.369	0.415	0.44	0.46	0.516	0.55	0.645
	↘	0.05	0.07	0.08	0.088	0.1	0.106	0.11	0.12	0.13	0.15
 SII	↖	0.421	0.59	0.66	0.737	0.83	0.88	0.92	1.03	1.1	1.29
	↘	0.1	0.14	0.16	0.176	0.2	0.21	0.22	0.25	0.26	0.31

Figure 39

4. The quick change gearbox there are four knobs, turn the first knob to “4” position, turn the second knob to “S” position, turn the third knob to “C” position and turn the fourth knob to “I” position. See **Figure 40**. Leaving 0.08mm–0.15mm backlash between gear teeth, arranges the 24 teeth change gear to 120 teeth and 120 teeth to 48 tooth change gear.

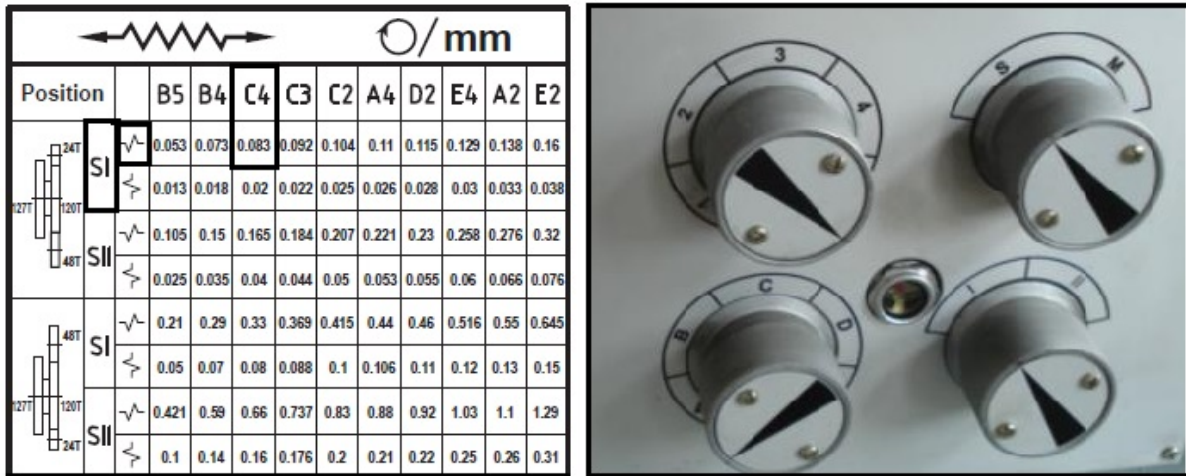

Figure 40

5. Rotate the spindle by hand to verify no binding exists, and close the gear door.

Thread settings

Regardless of the example given below, the setup procedure on this lathe is the same for metric, inch threads. These thread selections are indicated by a series of letters and numbers shown on the headstock threading charts. First, the change gear positions are checked and rearranged if indicated by the chart. Next, the quick change gearbox knobs and levers are moved to specific positions also indicated by the chart.

To set up for threading:

1. Disconnect lathe from power!
2. Open the change gear door on the left-hand side of the headstock to expose the change gears.
3. Review the threading chart for the required thread to be cut (see **Figure 41**). The chart indicates that to cut a 0.75 metric thread, the change gears and feed dials must be in the following positions:

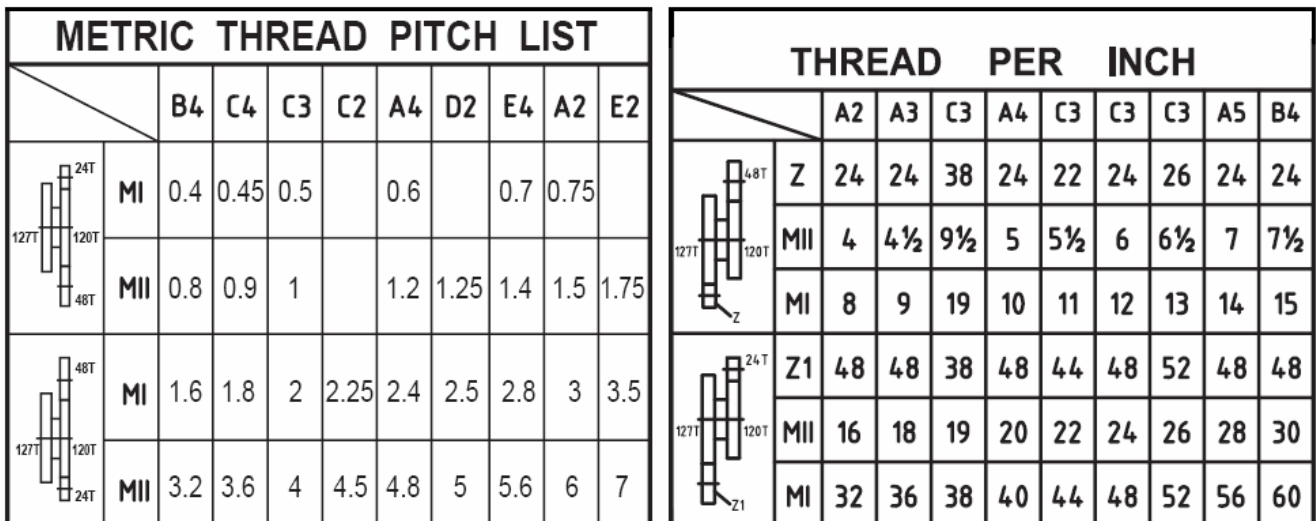

Figure 41

4. Turn the first knob of the quick change gearbox to “2” position, turn the second knob to “M” position, turn the third knob to “A” position and turn the fourth knob to “I” position. See **Figure 40**. Leaving 0.08mm–0.15mm backlash between gear teeth, arranges the 24 teeth change gear to 120 teeth and 120 teeth to 48 tooth change gear.
5. Rotate the spindle by hand to verify no binding exists, and close the gear door.

Feed direction lever

Selects the direction for power feed.(**See Figure 36**). When lever is positioned to the right side, the carriage will move to the left along the bed, or the cross feed will travel toward the front of the lathe. (**See Figure 42**)

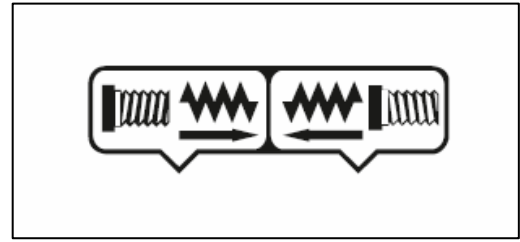

Figure 42

Feed selection lever

To prevent apron and drive system damage, the apron is equipped with an internal lockout, meaning that in order to engage the half nut for threading, this lever must be moved to the central or the disengaged position. Also keep in mind that just as with longitudinal feed operations, before any threading operation. You must first verify the carriage lock (see **Figure 43**) is disengaged, or the feed system may be damaged.

Half-nut lever

When the feed selection lever and carriage lock are disengaged, the half-nut lever (**Figure 43**) can be moved downward from the disengaged upper position to clamp the half nut around the leadscrew for threading operations.

CAUTION! Do not engage the half nut if the leadscrew will rotate over 200 rpm, or if the carriage lock is applied. Disregarding this warning may cause damage to the bearings or the leadscrew shear pin to break.

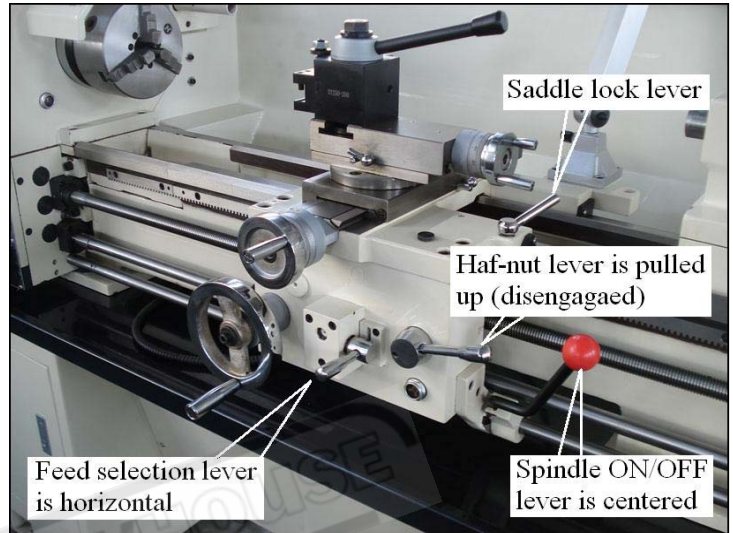

Figure 43

Thread dial

When cutting metric threads and the pass has been completed, the thread dial (**see Figure 44 & Figure 45**) allows the machinist to disengage the carriage from the leadscrew, and quickly return the carriage for the next pass. Based on the thread being cut, and what is indicated on the thread chart, the dial indicates where the machinist must re-clamp the half nut in order to resume the same thread to avoid cross-cutting threads. The thread dial chart is located on the quick change gearbox cover.

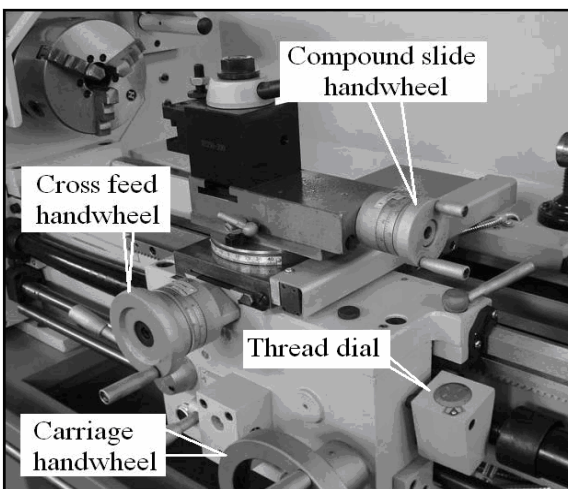

Figure 44

INDICATOR TABLE					
T	mm	SCALE	T	mm	SCALE
0	0.5	/	15	0.45	1
	0.6	/		0.9	1
	0.75	/		1.25	1
	1	/		1.8	1
	1.5	/		2.25	1
	3	/		2.5	1
16	0.4	1-8	14	4.5	1
	0.8	1,3,5,7		5	1
	1.2	1-8		0.7	1,5
	1.6	1,5		1.4	1,5
	2	1-8		1.75	1,5
	2.4	1,3,5,7		2.8	1
	3.2	1		3.5	1,5
	4	1,3,5,7		7	1,5
	4.8	1,5			
	6	1-8			

Figure 45

When cutting inch threads, the thread dial must be disengaged from the leadscrew, and the half nut clamped to the leadscrew until the threads are complete. Otherwise the path of the same thread will be lost. All carriage returns for non-metric threads are made by backing the tool point out of the thread, and reversing spindle rotation with the spindle **ON/OFF** lever.

To engage the thread dial, loosen the mounting cap screw, then pivot the dial into the leadscrew so the gear teeth mesh with the leadscrew. Retighten the cap screw to hold the thread dial in place.

SECTION 5: MAINTENANCE

Schedule

For optimum performance from your machine, follow this maintenance schedule and refer to any specific instructions given in this section.

Every 6–8 hours of running time:

- Clean/vacuum lathe.
- Wipe down unpainted cast iron, including leadscrew, with way oil or other quality metal protectant.
- lubricate ball oilers and change gears.
- Check oil reservoirs .

Each Week:

- Check cutting fluid system. Clean tank and replace cutting fluid as necessary.

Each month:

- Check/adjust v-belt tension.

Every six months:

- Change oil in headstock, gearbox, and apron.

Cleaning

Cleaning the lathe is relatively easy. Disconnect the lathe before cleaning it. Remove chips as they accumulate. Vacuum excess metal chips and wipe off the remaining cutting fluid with a dry cloth when finished for the day. Chips left on the machine soaked with water-based cutting fluid will invite oxidation and gummy residue to build up around moving parts. Preventative measures like these will help keep your lathe running smoothly. Always be safe and responsible with the use and disposal of cleaning products.

Ball oiler and change gears lubrication

When lubricating ball oilers, we recommend using an oil gun. See **Figure 46-50**.

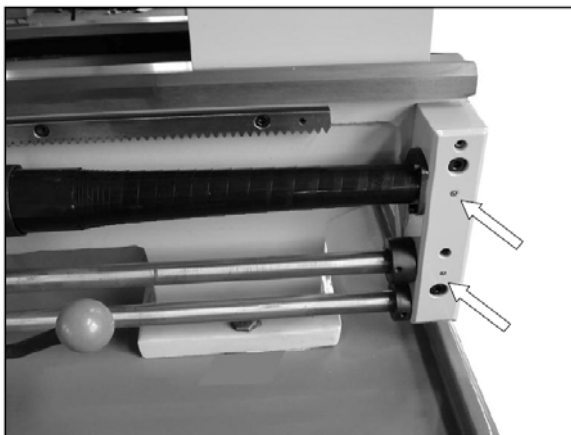

Figure 46



Figure 47

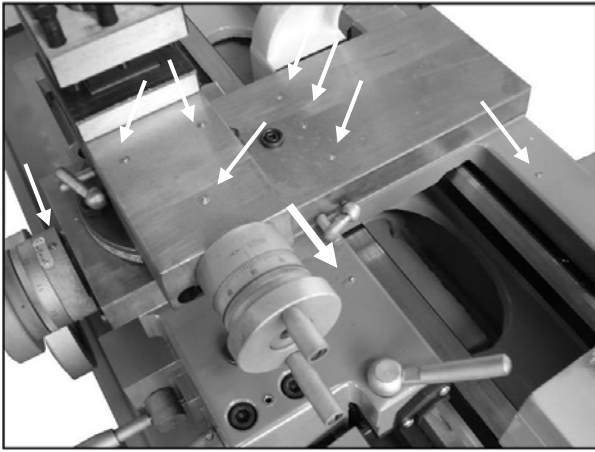

Figure 48

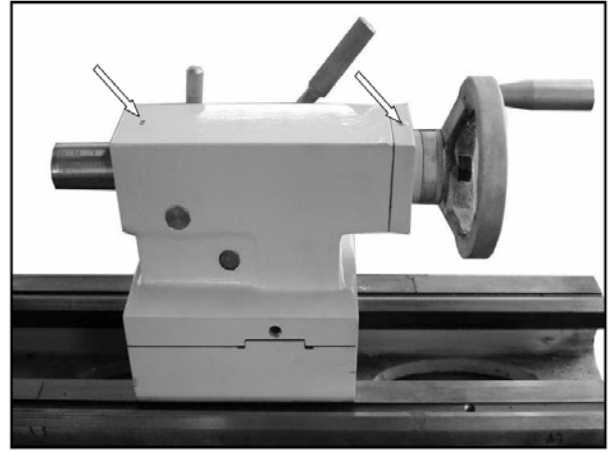

Figure 49



Figure 50

Oil Reservoirs

Checking & adding oil

The headstock, gearbox, and apron have oil reservoirs that are equipped with sight glasses for quickly checking oil levels. Before and after every use, make sure that the oil levels are correct. **Figures 51-56** show the gearbox locations of the sight glasses and the fill/drain plugs.

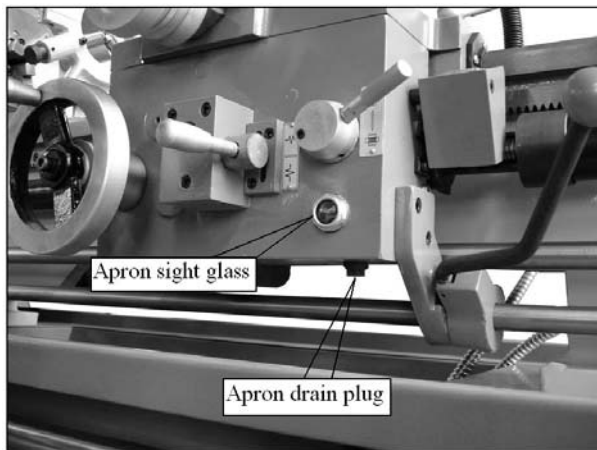

Figure 51

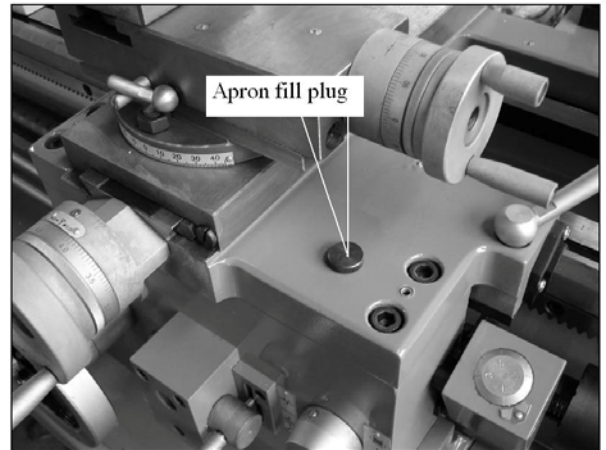

Figure 52

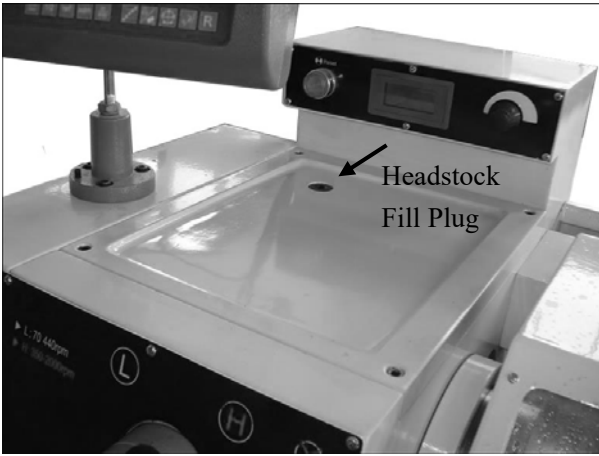

Figure 53

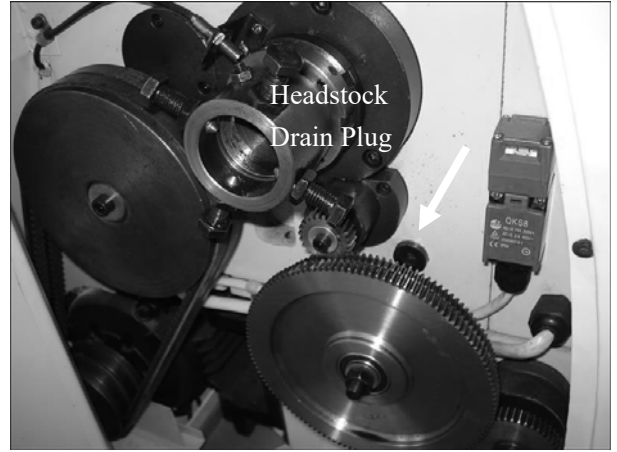

Figure 54

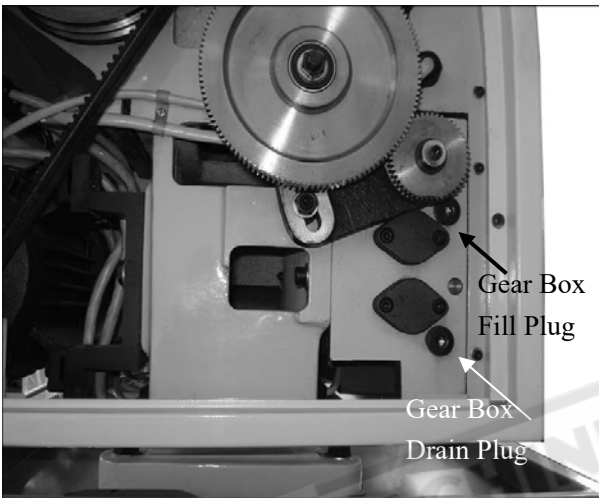

Figure 55



Figure 56

Recommended oil types

- Headstock.....ISO 32#
- QC gearboxISO 68#
- ApronISO 68#

To add oil to the reservoirs:

1. Clean the area around the fill plug clean to prevent debris from falling in the reservoir when adding oil.
2. Remove the fill plug.
3. Slowly add oil until the oil level is centered in the sight glass.
4. Replace fill plug.

Changing oil

The oil in the reservoirs must be changed after the first three months of operation, then twice a year after that. If the lathe is under heavy use, more frequent oil changes will be required to keep the gearboxes clean and ensure long machine life. Some lathe owners believe that by using full synthetic oils in the gearboxes is a way to extend oil change intervals. We do not recommend this practice. While synthetic oils are superior this lathe does not use a filter to remove contaminants that are generated during normal use, such as when shifting gears. Changing the oils on a frequent basis to flush out moisture and contaminants is still the best option to ensure long gearbox life.

- Headstock oil Capacity4 liters
- QC gearbox oil Capacity2 liters
- Apron oil Capacity1 liter

To change the oil in the reservoirs:

1. Run the lathe to bring the lathe gearboxes to a warm temperature and turn OFF the lathe.
2. Disconnect lathe From power!
3. Remove the headstock gear cover.
4. Using a funnel or cardboard ramp if desired to direct waste oil into the drain pan, position the drain pan under the gearbox drain plug.
5. Remove the fill plug and the drain plug from the selected oil reservoir, and allow all oil to drain.
6. Re-install the drain plug; add oil to the reservoir until the sight glass reads full. Then reinstall the fill plug.

V-belt tension

After initial break in, the v-belts slightly stretch and seat into the pulley. It is important to check and adjust them to compensate for this initial wear. Check the tension thereafter on a monthly basis.

To check the v-belt tension:

1. Disconnect lathe from power!
2. Open the headstock gear door.
3. Push the center of the v-belts with moderate pressure. The v-belt deflection should be approximately 10mm.

See **Figure 57**

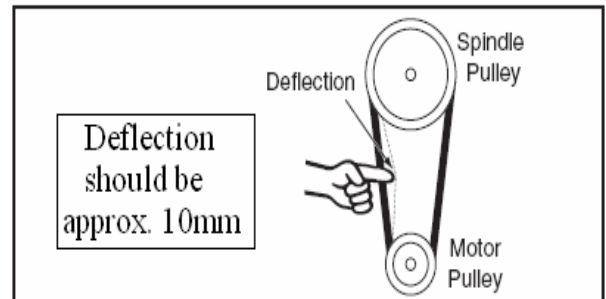

Figure 57

—if the belt deflection is greater than 10mm, use the wrench to loosen the motor mount bolts (**Figure 58**) and slide the motor downward until the deflection is correct.

4. Tighten the bolts and recheck the belts.

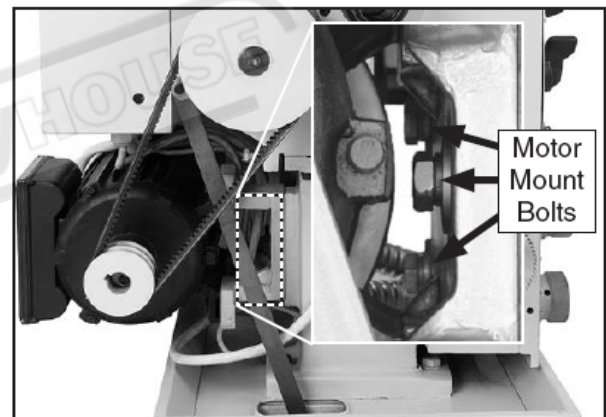

Figure 58

Cutting fluid system

WARNING! Biological and poison hazard! Use the correct personal protection equipment when handling cutting fluid and by fluid manufacturer requirements to properly dispose of cutting fluid.

Checking cutting fluid system

When checking the cutting fluid system, the goal is to make sure there is enough cutting fluid, the chip level in the first chamber is not too high, and the cutting fluid has not become rancid or contaminated.

To check the cutting fluid system:

1. Disconnect lathe from power!
2. At the tailstock end of the lathe, remove the pump access cover.
3. Inspect the level of cutting fluid inside the tank. The cutting fluid should be approximately an inch below the top of the tank.
4. Using a wooden stick, check the level of the metal chips in the first chamber (**see Figure 59**). If the chips are $\frac{3}{4}$ the height of the baffle, then remove the chips.

5. Inspect the cutting fluid quality as outlined by the fluid manufacturer and replace as recommended.

Cleaning cutting fluid system

1. Place the drain hose on the end of the coolant nozzle, and pump the used cutting fluid into the drain bucket. As soon as pumping is complete turn **OFF** pump immediately.
2. Disconnect lathe from power!
3. Lift the tank assembly from the lathe stand.
4. Remove all metal shavings, any remaining cutting fluid, and clean out the tank using rags and mineral spirits.
5. Clean the intake screen on the pump.
6. Reinstall the cutting fluid tank into the lathe stand.
7. Cutting fluid to the manufacturer's required specific gravity, and fill the cutting fluid tank with the cutting fluid.
8. Reinstall the pump access cover.

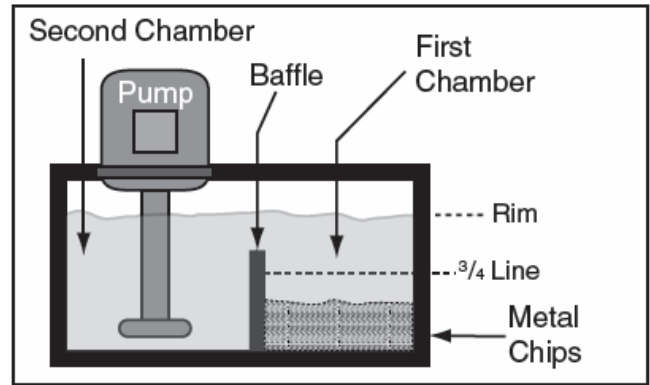

Figure 59

SECTION 6: SERVICE

Troubleshooting

review the troubleshooting and procedures in this section to fix your machine if a problem develops. If you need replacement parts or you are unsure of your repair skills, then feel free to call our technical support.

Motor & gearbox

Symptom	Possible Cause	Possible Solution
Motor will not start.	<ol style="list-style-type: none"> 1. Stop button not reset. 2. Main power panel switch is OFF. 3. Circuit breaker or fuse has tripped. 4. No voltage or open connection. 5. Capacitor is at fault. 6. Spindle ON/OFF switch is at fault. 7. Power switch or magnetic contactor is at fault. 8. Motor is at fault. 	<ol style="list-style-type: none"> 1. Reset stop button. 2. Turn the main power panel switch ON. 3. Seek an electrician to troubleshoot and repair the power supply. 4. Test circuit, replace wires and connections as required 5. Replace capacitor. 6. Replace switch. 7. Replace power switch or magnetic contactor. 8. Replace motor.
Fuses or circuit breakers trip open.	<ol style="list-style-type: none"> 1. Short circuit in power cord or plug. 2. Short circuit in motor or loose connections. 3. Incorrect fuses or circuit breakers in power supply. 	<ol style="list-style-type: none"> 1. Inspect cord or plug for damaged insulation and shorted wires, repair or replace as required. 2. Inspect all connections on motor for loose or shorted terminals or worn insulation. Repair as required 3. Install correct fuses or circuit breakers.
Machine is loud; belt slips when cutting. Overheats or bogs down in the cut.	<ol style="list-style-type: none"> 1. Excessive depth of cut. 2. RPM or feed rate wrong for operation. 3. Dull bit. 4. Belt is slipping. 5. Belt is at fault. 	<ol style="list-style-type: none"> 1. Decrease depth of cut. 2. Refer to RPM feed rate chart for appropriate rates, 3. Sharpen or replace bit. 4. Remove grease or oil on belt tighten belt adjustment 5. Replace belt.
Gear change levers will not shift into position.	<ol style="list-style-type: none"> 1. Gears not aligned in headstock. 	<ol style="list-style-type: none"> 1. Rotate spindle by hand until gear falls into place.
Loud, repetitious noise coming from machine at or near the motor.	<ol style="list-style-type: none"> 1. Pulley set screws or keys are missing or loose. 2. Motor fan is hitting the cover. 	<ol style="list-style-type: none"> 1. Inspect keys and set screws. Replace or tighten if necessary. 2. Replace fan and cover as required.

Operation and Work results

Symptom	Possible Cause	Possible Solution
Entire machine vibrates excessively upon startup and while running.	<ol style="list-style-type: none"> 1. Workpiece is unbalanced. 2. Worn or broken gear present. 3. Chuck or faceplate has become unbalanced. 4. Spindle bearings at fault. 	<ol style="list-style-type: none"> 1. Reinstall workpiece so it is as centered with spindle centerline. 2. Inspect gears and replace if necessary. 3. Rebalance chuck or faceplate; contact a local machine shop for help. 4. Adjust or replace spindle bearings.
Cutting tool or machine components vibrate excessively during cutting.	<ol style="list-style-type: none"> 1. Tool holder not tight enough. 2. Cutting tool sticks too far out of tool holder; lack of support. 3. Gibs are out of adjustment. 4. Dull cutting tool. 5. Incorrect spindle speed or feed rate. 	<ol style="list-style-type: none"> 1. Check for debris, clean, and retighten. 2. Reinstall cutting tool so no more than 1/8 of the total length is sticking out of tool holder. 3. Tighten gib screws at affected slide 4. Replace or re sharpen cutting tool. 5. Use the recommended spindle speed or feed rate
Can't remove tapered tool from tailstock quill.	<ol style="list-style-type: none"> 1. Quill had not retracted all the way back into the tailstock. 2. Debris is binding arbor in quill. 3. Incorrect arbor or tooling inserted into quill. 	<ol style="list-style-type: none"> 1. Turn the quill handwheel until it forces taper out of quill. 2. Extend quill to expose drift slot and use drift key to remove arbor. 3. Remove quill and drive out tooling or arbor with punch.
Cross slide, compound rest, or carriage feed has sloppy operation.	<ol style="list-style-type: none"> 1. Gibs are out of adjustment. 2. Handwheel is loose or has excessive backlash. 3. Leadscrew mechanism worn or out of adjustment. 	<ol style="list-style-type: none"> 1. Tighten gib 2. Tighten screws and adjust backlash 3. Tighten any loose fasteners on leadscrew mechanism.
Cross slide, compound rest, or carriage feed handwheel is hard to move.	<ol style="list-style-type: none"> 1. Gibs are loaded up with shavings or grime. 2. Gibs are too tight, gib lock or carriage lock is applied. 3. Backlash setting too tight (cross slide only). 4. Bedways are dry. 	<ol style="list-style-type: none"> 1. Remove gibs, clean ways/dovetails, lubricate, and readjust gibs. 2. Loosen gib adjustment and gib locks, release carriage lock 3. Slightly loosen backlash setting 4. Lubricate bedways and handles.
Bad surface finish.	<ol style="list-style-type: none"> 1. Wrong RPM or feed rate. 2. Dull tooling or poor tool selection. 3. Too much play in gibs. 4. Tool too high. 	<ol style="list-style-type: none"> 1. Adjust for appropriate RPM and feed rate. 2. Sharpen tooling or select a better tool for the intended operation. 3. Tighten gibs 4. Lower the tool position.
Inaccurate turning results from one end of the workpiece to the other.	<ol style="list-style-type: none"> 1. Headstock and tailstock are not properly aligned with each other. 	<ol style="list-style-type: none"> 1. Realign the tailstock to the headstock spindle bore center line
Chuck jaws won't move or don't move easily.	<ol style="list-style-type: none"> 1. Chips lodged in the jaws. 	<ol style="list-style-type: none"> 1. Remove jaws, clean and lubricate chuck threads, and replace jaws.
Carriage won't auto feed, or overloads the spindle motor.	<ol style="list-style-type: none"> 1. Carriage or gib lock is applied. 2. Gears are not all engaged or broken. 3. Gibs are too tight. 4. Leadscrew shear pin has sheared. 	<ol style="list-style-type: none"> 1. Release locks. 2. Adjust gear positions or replace. 3. Loosen gib screw(s) slightly 4. Correct the cause of shear pin breakage, and replace shear pin.
Tailstock quill will not feed out of tailstock.	<ol style="list-style-type: none"> 1. Quill lock lever is tightened down. 	<ol style="list-style-type: none"> 1. Turn lever counterclockwise.

Gib adjustments

The cross-slide and compound slide on this lathe each use a long steel wedge called a gib that is positioned between the component and its dovetailed-ways. At the end of each gib is a gib screw one of which is shown in **Figure 60**. The screws at each end of the gib oppose one another to move and hold the gib in a forward or aft position. Depending which direction the gib is moved and held, the space between the sliding ways is increased or decreased to control the rigidity of the cross slide and compound slide.

Before adjusting gibs, consider the lathe operation that you will perform because the cross slide and compound rest leadscrew nuts may also have to be adjusted.

- For heavy turning and facing loads, tighten gibs for maximum rigidity, and loosen the leadscrew nuts for shock loading protection.
- For high-tolerance turning and facing, and light-loads, loosen the gibs to allow for small slide movements without binding or tool bit leap, and tighten the leadscrew nuts for fine handwheel control.

Most lathe operations exist between the two examples above. Finding the optimum combination for your requirements may take practice, and trial and error before you are satisfied.

NOTICE! When adjusting gibs, keep in mind that the goal of gib adjustment is to remove unnecessary sloppiness from the slide without causing binding and excessive half nut wear.

Tip: The compound and cross slide gibs have a gib lock screw that are shown in **Figures 60-61**. This screw allows the machinist to quickly tighten the locks to hold a gib and slide in a rigid position without having to tighten the gibs. When finished with the need for increased rigidity, the gibs then are quickly unloaded back to their normal state by loosening the screw.

Cross slide gib

Make sure the ways and leadscrew have been cleaned and re-lubricated before beginning any adjustments.

To adjust the cross slide gib:

1. Disconnect lathe from power!
2. Loosen the gib lock shown in **Figure 60**
3. Loosen gib screw and adjust as required.
 - to increase the slide tension, loosen the rear gib screw 1/8-turn, and tighten the front gib screw 1/8-turn.
 - to decrease the slide tension, loosen the front gib screw 1/8-turn, and tighten the rear gib screw 1/8-turn.
4. Repeat adjustments as necessary until the gib screw drag is acceptable.

Compound slide gib

Figure 61 shows the gib arrangement for the compound slide. the compound slide gib adjusts in the same manner and with the same tools as the cross slide gib. However, in this case, to increase or decrease tension, the gib adjustment screw directions are reversed.

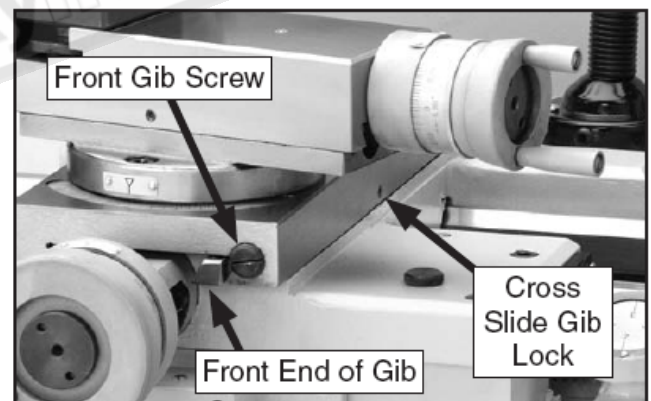

Figure 60

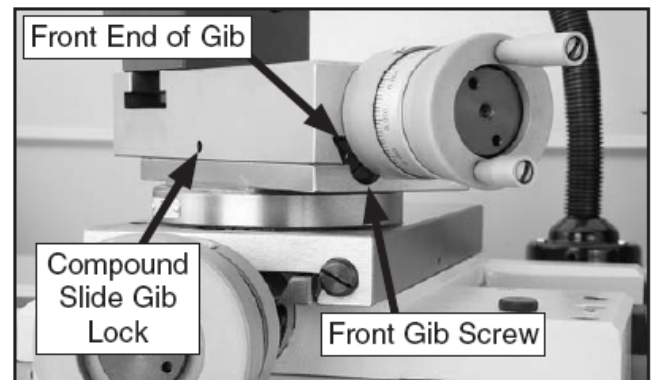

Figure 61

Saddle gib

The saddle is supplied with a carriage lock on the front right-hand side of the slide (see **Figure 62**). This bolt locks the saddle in place for increased rigidity when making face cuts. Before making adjustments to the saddle gib, make sure that this lock is loose by turning it counterclockwise .

The saddle gib is located on the bottom of the back edge of the slide (**Figure 64**). This gib is designed differently than the cross or compound slide gibs. instead of being a wedge-shaped plate, it is a flat bar. the gib pressure is applied by four set screws. hex nuts secure these set screws in place, so they will not loosen during operation.

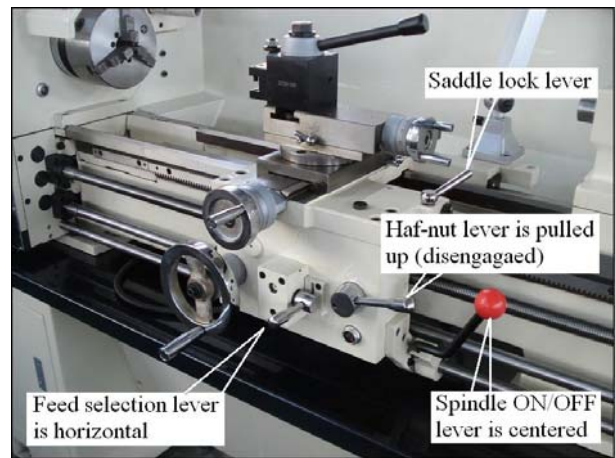

Figure 62

To adjust the saddle slide gib:

1. Disconnect lathe from power!
2. Clean and lubricate the lathe ways, slide, and leadscrew.
3. If the carriage lock is tight, loosen it two turns.
4. Loosen the jam nuts on the four set screws shown in **Figure 63**, and adjust the set screws as follows:
 - to tighten the carriage gib, tighten the set screws.
 - to loosen the gib, loosen the set screws.
5. Repeat adjustments as necessary until the carriage adjustment is acceptable.
6. Hold the set screws in place and tighten the jam nuts.

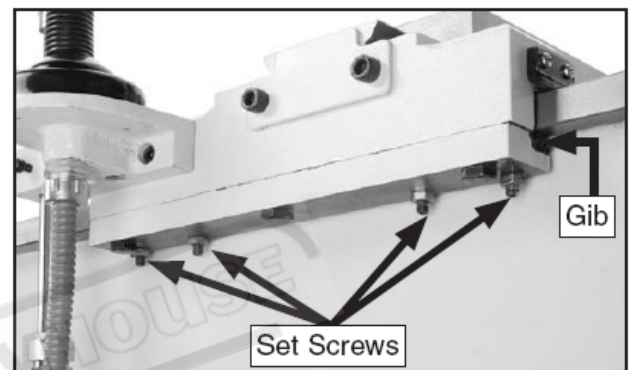

Figure 63

Backlash adjustment

Backlash is the amount of play in a leadscrew and can be felt as the free play in a handwheel when changing direction of rotation. The amount of the backlash can be viewed on the handwheel micrometer-collar.

When adjusting backlash, tighten the components enough to remove backlash, but not so much that the components bind the leadscrew, making it hard to turn. Over tightening will cause excessive wear to the sliding block and leadscrew.

To adjust the cross slide backlash:

1. Feed the cross slide backwards (toward the front of the machine) until it reaches the end of its travel.
2. Remove the cap screw that secures the cross slide leadscrew nut (see **Figure 64**).



Figure 64

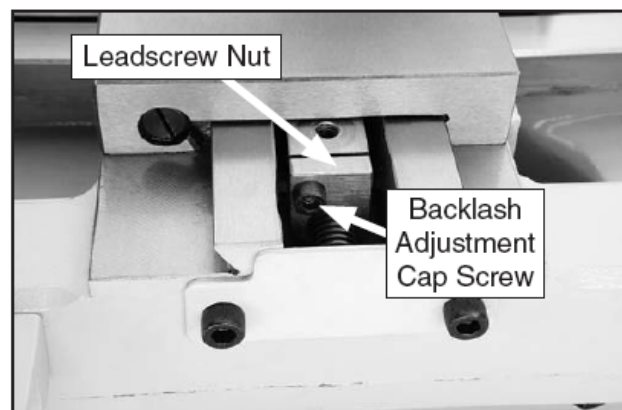

Figure 65

3. Rotate the cross slide handle clockwise to feed the leadscrew nut out from under the cross slide, as shown in **Figure 65**
4. Tighten the backlash adjustment cap screw shown in **Figure 65** in small increments.
5. Hold the leadscrew nut and test after each adjustment by rotating the handwheel back-and-forth until the backlash amount is acceptable.
6. Feed the leadscrew nut back under the cross slide and replace the cap screw removed in **step 2**.

Half nut adjustment

The half-nut mechanism can be adjusted if it becomes loose from wear. The half nut is mounted in ways with a gib exerting pressure between components to reduce sloppy movement. The half-nut gib is a flat bar-type gib, similar to the saddle gib, and is tensioned with three set screws.

To adjust the half nut:

1. Disconnect lathe from power!
2. Open the half nut and remove the thread dial.
3. Loosen the hex nuts on the set screws shown in **Figure 66**
4. Tighten each set screw approximately 1/8 of a turn, then retighten the hex nuts without moving the set screws.
5. Move the carriage handwheel until the half nut can fully close, then open/close the half nut several times and notice how it feels. The half nut is correctly adjusted when you feel a slight drag while opening and closing it. It should not feel too stiff or too loose.
6. Repeat **steps 3–5**, if necessary, until you are satisfied with the half nut adjustment, then reinstall the thread dial.

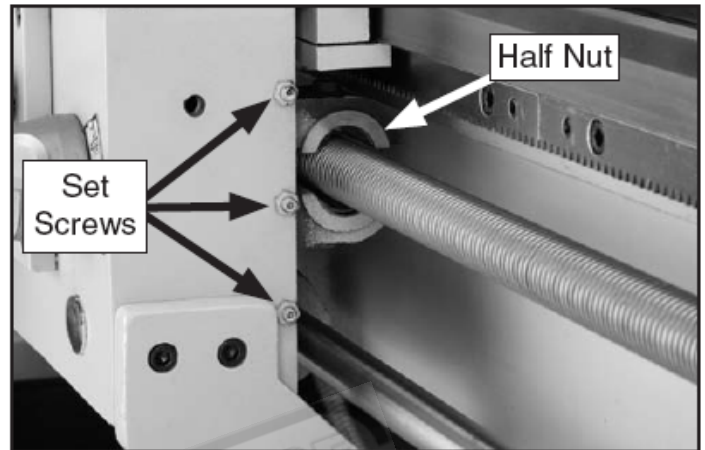

Figure 66

Feed clutch adjustment

This lathe is equipped with a feed rod clutch, shown in **Figure 67-68**, that connects the feed drive hub with the feed rod through a set of spring-loaded internal balls. This clutch helps protect the apron feed system from overload. The feed rod clutch comes set from the factory, and unless there is a problem, it needs no adjustment.

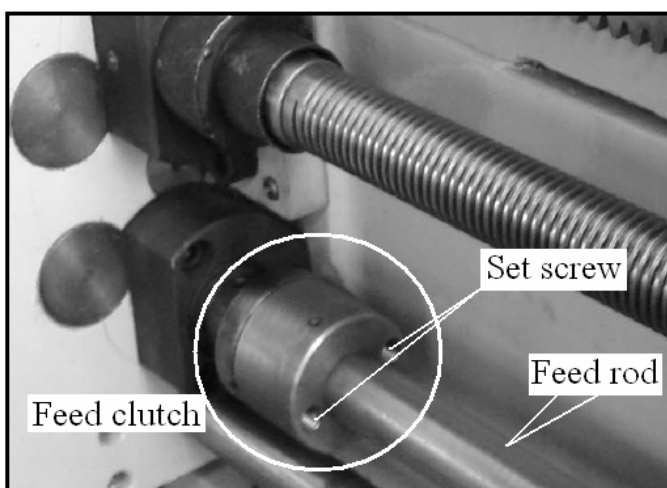

Figure 67

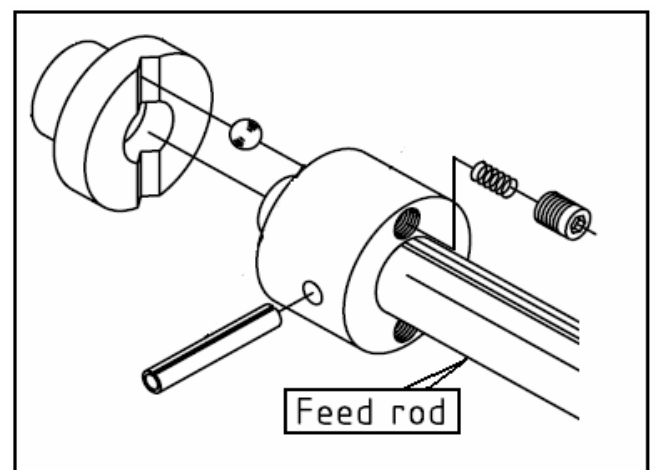

Figure 68

The clutch may slip if the path for the carriage or the cross feed is obstructed during turning or facing operations, the tool bit crashes into a workpiece shoulder, the carriage lock is left applied when the feed selection lever is engaged, or if too deep of a cut is taken, causing a sudden binding of the tool and workpiece.

It is imperative to recognize however, the clutch is not a foolproof way of protecting your lathe from damage if an operational mistake is made, a chuck-carriage crash occurs, or general machine overloading occur on a regular basis. Never completely tighten the feed clutch set screw past its normal setting outlined in this procedure in an attempt to completely eliminate clutch slip. Doing so will void the warranty, and can lead to a non-slipping clutch, resulting in catastrophic gearbox damage.

To adjust the feed rod clutch:

Disconnect lathe from power!

—if the clutch slips during normal work loads and no problem exists with the feed system, the clutch spring pressure must be increased. Tighten the two set screws 1/8-turn and recheck for slippage.

—if for any reason the clutch is bound up or locked, and does not slip when it should, the clutch spring pressure must be reduced. Loosen the two set screws 1/8-turn, and recheck for slippage.

Tailstock lock

When pushed toward the spindle, the tailstock lock holds the tailstock firmly in place on the bedway with a locking plate underneath. If the position of the lock lever is difficult to use, the lever can be adjusted for the best leverage.

To adjust the tailstock lock lever:

1. Unthread the stop pin (see **Figure 69**), and carefully slide the tailstock from the lathe.
2. Tighten the hex nut 1/4-turn and reinstall the tailstock.
3. Apply the tailstock lock lever and verify that the tailstock is locked and the lever is where desired. Readjust as necessary.

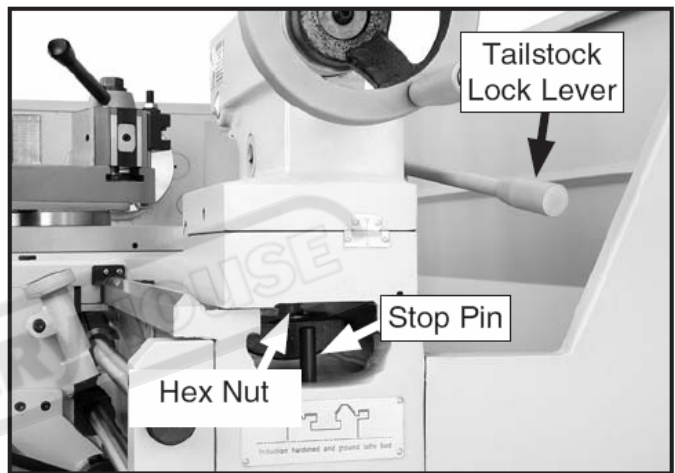

Figure 69

Gap insert removal

This lathe is equipped with a removable gap insert that will allow for turning large diameter workpieces. The gap was seated, pre-loaded, and then ground for precise mating and alignment at the factory. Removing the gap can cause the lathe insert to slightly spring out of shape. When reinstalled, there is no guarantee that original alignment and flush mating will be the same. For this reason, removing the gap is considered a permanent alteration to the lathe, even if it is later reinstalled.

To remove the gap:

1. Disconnect lathe from power!
2. Loosen the preload set screw a few turns until it no longer contacts the headstock (see **Figure 70**).
3. Tighten the dowel-pin jack nut to draw the pins from the gap.
4. Remove the four cap screws that secure the gap to the bed.
5. Tap the outside of the gap piece with a dead blow hammer to loosen it, and, with the help of another person, remove the gap piece.

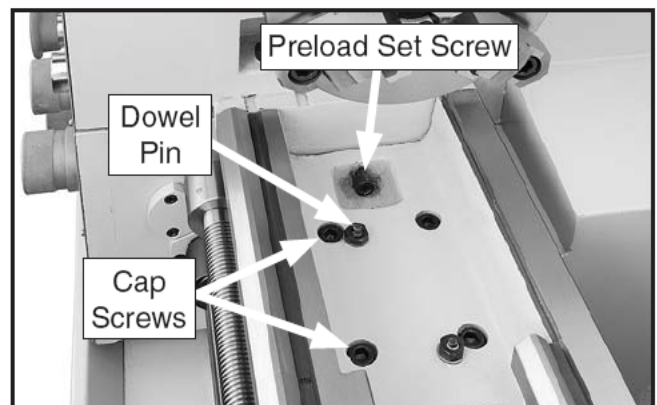

Figure 70

Machine storage

If the machine is not properly prepared for storage, it may develop rust or corrosion. Use the recommendations in this section to ensure that the lathe remains in good condition for later use.

To prepare your machine for short-term storage (up to a year):

1. Pump out the old cutting fluid, and remove and blow out lines with compressed air and a few drops of way oil.
2. Disconnect lathe from power!
3. Thoroughly clean all unpainted, bare metal surfaces, then apply a liberal coat of way oil.
4. Lubricate the machine as outlined in the lubrication section. Be sure to use the oil gun to purge all ball oilers and the oil passages with oil.
5. Cover and place the machine in a dry area that is out of direct sunlight and away from hazardous fumes, paint, solvents, or gas. Fumes and sunlight can bleach or discolor paint and make plastic guards cloudy.
6. Once or twice a month, depending on the ambient humidity levels in the storage environment, wipe down the machine as outlined in step 3. Slide the carriage, tailstock, and steady rest down the lathe bed to make sure that way spotting is not beginning to occur.
7. Every few months, manually rotate all gear driven components a few times in several gear selections. This will keep the bearings, bushings, gears, and shafts well lubricated and protected from corrosion, especially during the winter months.

To prepare your machine for long-term storage (a year or more):

1. Run the lathe and bring all gearboxes to operating temperature, then drain and refill the all gearboxes with fresh oil.
2. Pump out the old cutting fluid, remove the lines, add a few drops of way oil into the lines, and blow out the lines with compressed air.
3. Disconnect lathe from power!
4. Thoroughly clean all unpainted, bare metal surfaces, then apply a liberal coat of way oil, a heavy grease, or rust preventative. Take care to ensure these surfaces are completely covered but that the rust preventative or grease is kept off of painted surfaces.
5. Lubricate the machine as outlined in the lubrication section. Be sure to use the oil gun to purge all ball oilers and the oil passages with oil.
6. Loosen or remove machine belts so they do not become stretched during the storage period. (Be sure to also affix a maintenance note near the power button as a reminder that the belts have been loosened or removed.)
7. Place a few moisture-absorbing desiccant bags inside of the electrical box.
8. Cover and place the machine in a dry area that is out of direct sunlight and away from hazardous fumes, paint, solvents, or gas. Fumes and sunlight can bleach or discolor paint and make plastic guards cloudy.
9. Slide the carriage, micrometer stop, tailstock, and steady rest down the lathe bed to make sure that way spotting is not beginning to occur.

BED ASSEMBLY

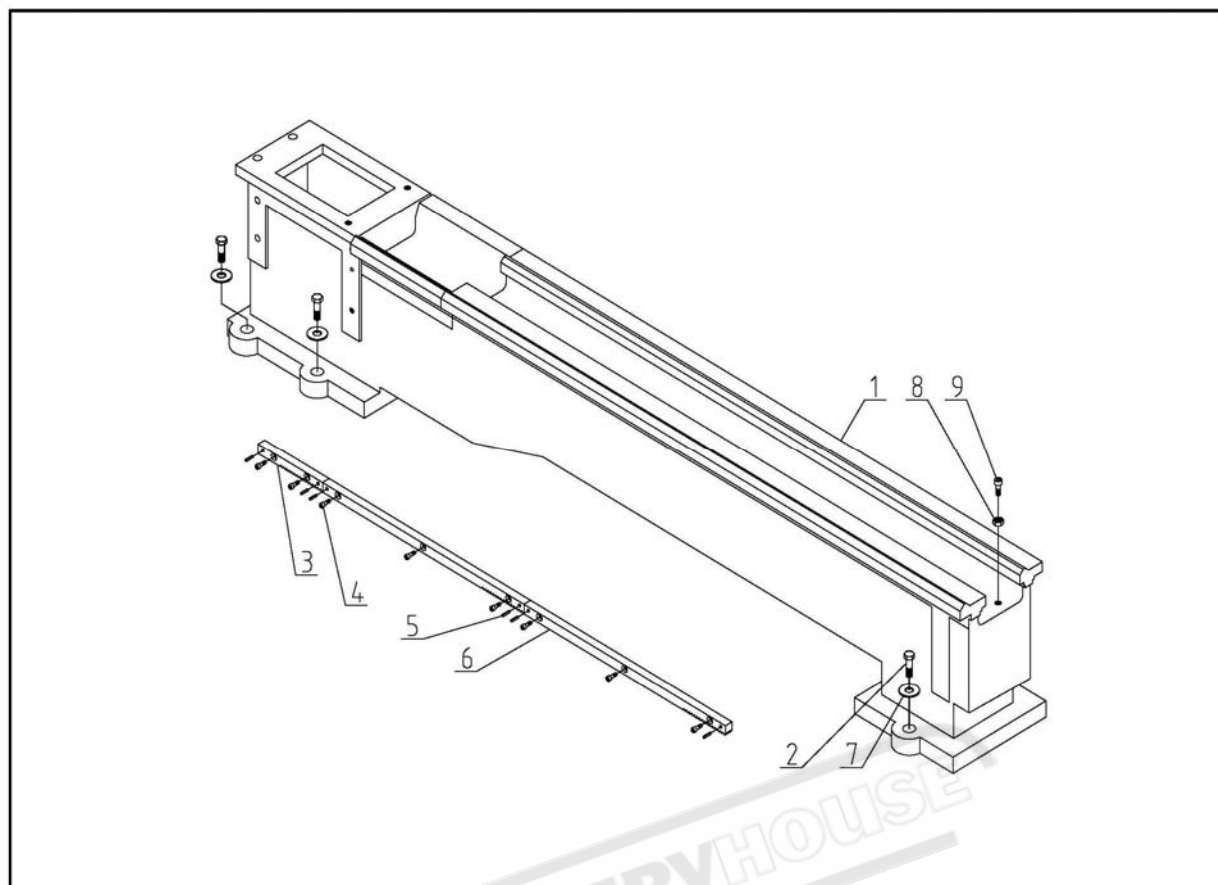

Index No	Part No	Description	Size	Qty
1	D330AV-11101	Lathe Bed		1
2	GB/T5782-M12X40	Screw	M12X40	6
3	D330A-11205	Rack Gear		1
4	GB/T70-M6X15	Hex Socket Cap Screw	M6X15	8
5	GB/T879-6X25	Pin	6X25	6
6	D330A-11204	Rack Gear		2
7	GB/T97.1-12	Washer	12	6
8	GB/T6170-M10	Nut	M10	1
9	GB/T70-M10X35	Hex Socket Cap Screw	M10X35	1

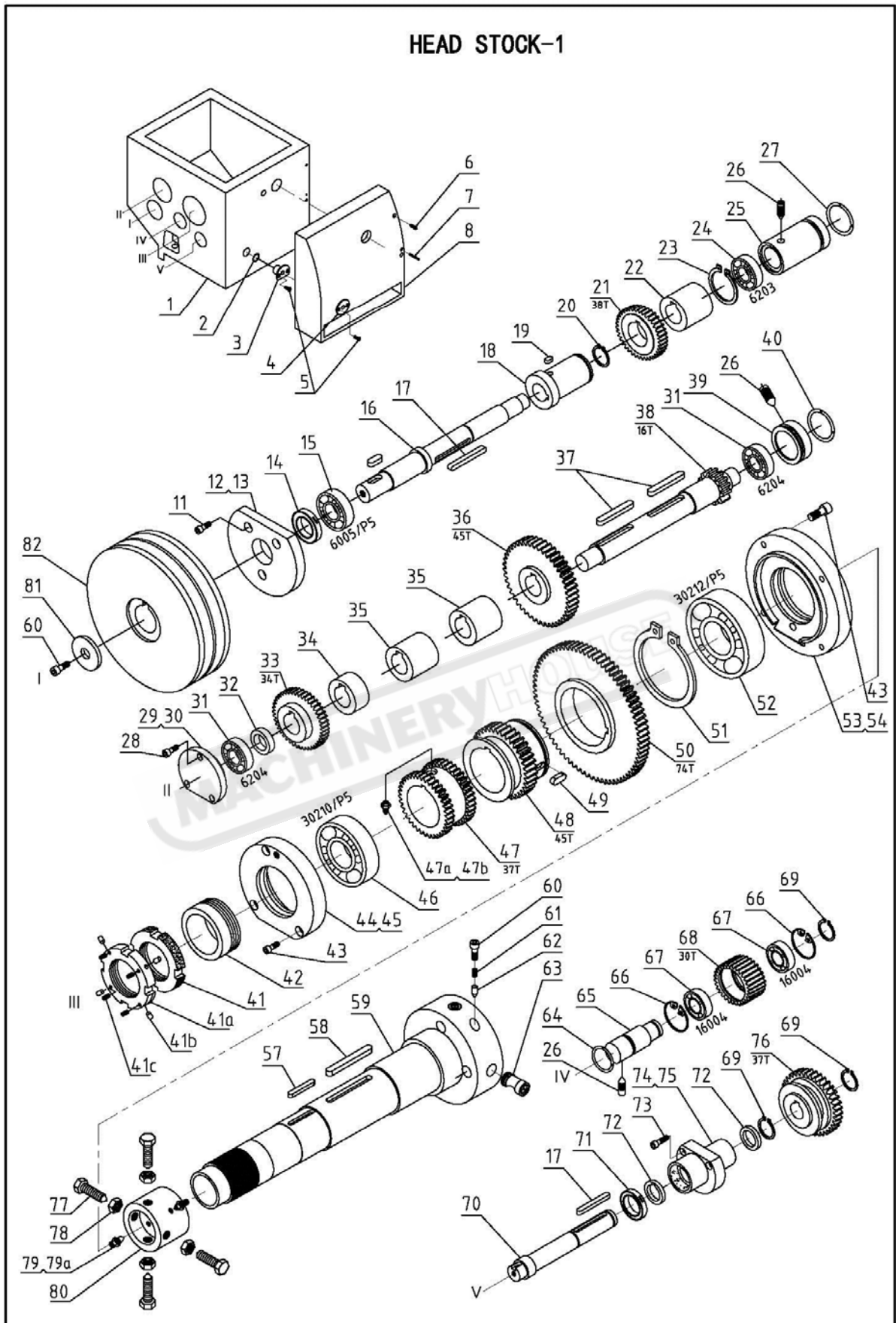

HEAD STOCK-1

Index No	Part No	Description	Size	Qty
1	D330A-21107	Head Stock		1
2	GB/T3452.1-20X2.65	Oil seal	20X2.65	1
3	D330A-21246	Sleeve		1
4	D330A-21235	Sleeve		1
5	GB/T819-M4X8	Screw	M4X8	4
6	GB/T70-M6X40	Hex Socket Cap Screw	M6X40	4
7	GB/T879-5X40	Pin	5X40	2
8	D330A-21113-2	Case frame		1
11	GB/T70-M6X20	Hex Socket Cap Screw	M6X20	3
12	D330A-21124	Cover		1
13	D330A-21601	Gasket		1
14	GB/T9877.1-25X40X7	Oil seal	25X40X7	1
15	GB/T276-6005	Bearing	6005	1
16	D330DV-21215	Shaft		1
17	GB/T1096-A6X50	Key	A6X50	2
18	D330DV-21217	Washer		1
19	GB/T1096-A6X10	Key	A6X10	1
20	GB/T894.1-22	Circlip	22	1
21	D330A-21220	Gear	38T	1
22	D330DV-21221-1	Washer		1
23	GB/T894.1-35	Circlip		1
24	GB/T276-6203	Bearing	6203	1
25	D330A-21106	Front plug		1
26	GB/T78-M8X16	Screw	M8X16	3
27	GB/T3452.1-40X3.1	Oil seal	40X3.1	1
28	GB/T70-M4X12	Hex Socket Cap Screw	M4X12	3
29	D330A-21104	Cover		1
30	D330A-21602	Gasket		1
31	GB/T276-6204	Bearing	6204	2
32	D330A-21211	Washer		1
33	D33D-21223	Gear	34T	1
34	D330DV-21221	Washer		1
35	D330D-21221	Washer		2
36	D330D-21224	Gear	45T	1
37	GB/T1096-A8X55	Key	A8X55	2
38	D330A-21212	Gear Shaft	16T	1
39	D330A-21225	Front plug		1
40	GB/T3452.1-47X3.1	Oil seal	47X3.1	1
41	D330A-21208	Nut		1
41a	D330AV-21208	Nut		1
41b		Magnet	φ 5X7	4

Index No	Part No	Description	Size	Qty
41c	GB77-M4X6	Screw	M4X6	4
42	D330A-21102	Collar		1
43	GB/T70-M6X25	Hex Socket Cap Screw	M6X25	7
44	D330A-21103	End cover		1
45	D330A-21603	Gasket		1
46	GB/T297-30210/P5	Bearing	30210/P5	1
47	D330A-21207A	Gear	37T	1
47a	GB/T78-M4X10	Screw	M4X10	1
47b	GB/T6170-M4	Nut	M4	1
48	D330AV-21227	Gear	45T	1
49	GB/T1096-A8X18	Key	A8X18	1
50	D330A-21226	Gear	74T	1
51	GB/T894.1-72	Circlip	72	1
52	GB/T297-30212/P5	Bearing	30212/P5	1
53	D330A-21108	Front cover		1
54	D330A-21605	Gasket		1
57	GB/T1096-A6X40	Key	A6X40	1
58	GB/T1096-A8X85	Key	A8X85	1
59	D330A-21228A	Spindle		1
60	GB/T70-M8X16	Hex Socket Cap Screw	M8X16	4
61	GB2089-4.5X16X0.8	Spring	4.5X16X0.8	3
62	D330A-21230	Pin		3
63	D330A-21231	Cam		3
64	GB/T3452.1-25X2.4	Oil seal	25X2.4	1
65	D330A-21238	Shaft		1
66	GB/T893.1-42	Circlip	42	2
67	GB/T276-16004	Bearing	16004	2
68	D330A-21237	Gear	30T	1
69	GB/T894.1-20	Circlip	20	3
70	D330A-21239	Shaft		1
71	GB/T9877.1-24X32X5	Oil seal	24X32X5	1
72	D330A-21202	Washer		2
73	GB/T70-M5X16	Hex Socket Cap Screw	M5X16	3
74	D330A-21101	Cover		1
75	D330A-21604	Gasket		1
76	D330A-21201	Gear	37T	1
77	D330A-21302	Screw		4
78	GB/T6172-M10	Gear	M10	4
79	GB/T78-M6X16	Screw	M6X16	2
79a	GB/T6170-M6	Nut	M6	2
80	D330A-21301A	Washer		1
81	GB/T96-8	Washer	8	1
82	D330A-21105	Pulley		1

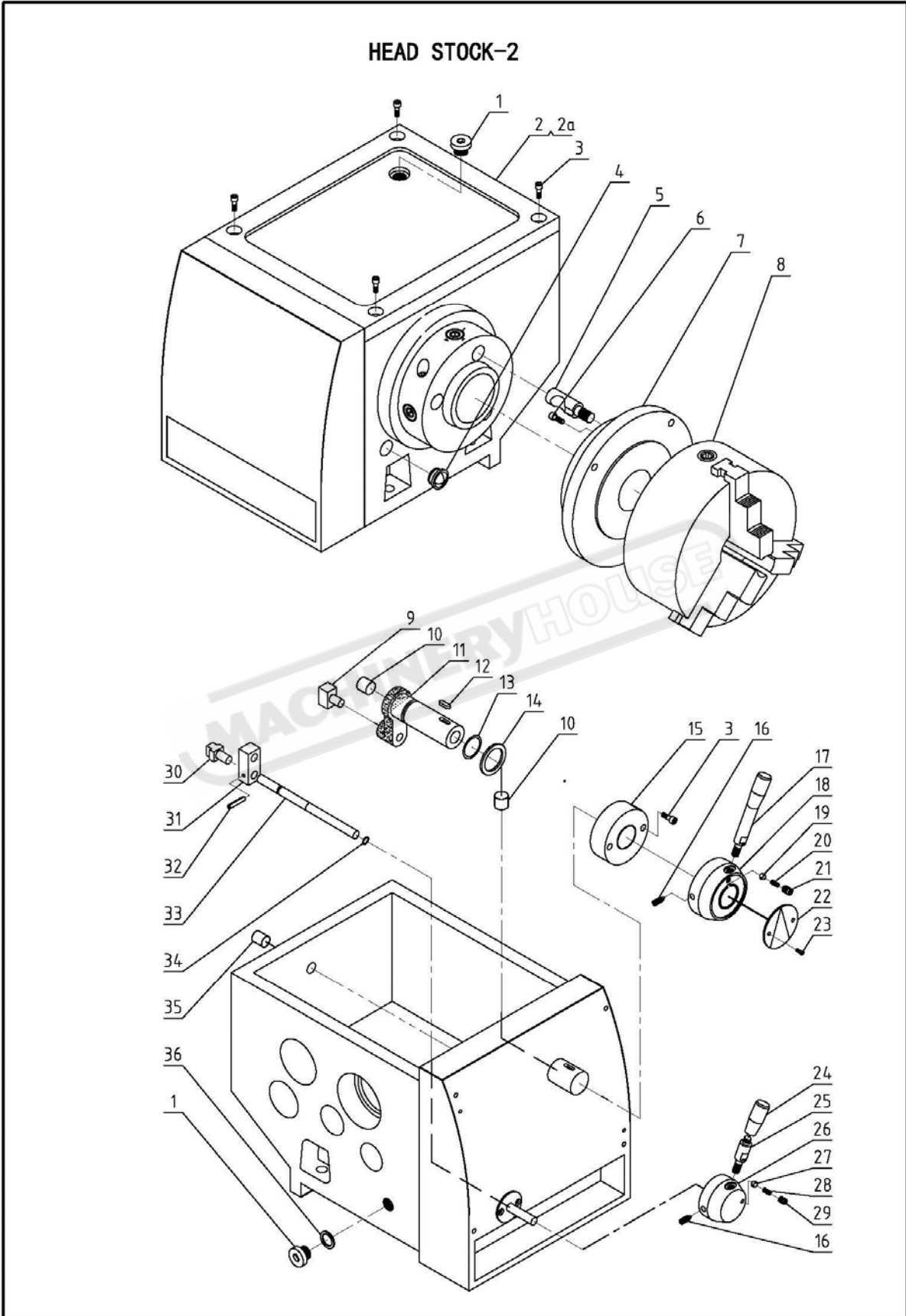

HEAD STOCK-2

Index No	Part No	Description	Size	Qty
1		Hexagonal socket head	M16X1.5	2
2	D330A-21112-1	Cover board		1
2a	D330A-21606	Gasket		1
3	GB/T70-M6X25	Hex Socket Cap Screw	M6X25	6
4	JB/T7941.2-M16X1.5	Oil sight	M16X1.5	1
5	D330A-81201	Cam lock stud		3
6	GB/T70-M6X12	Hex Socket Cap Screw	M6X12	3
7		Back Plate For 3-Jaw		1
8		Three jaw chuck		1
9	D330A-21403	Shift fork		1
10	D330DV-21233	Front plug	φ 16	2
11	D330AV-21121	Shift collar		1
12	GB/T1096-A5X14	Key	A5X14	1
13	GB/T3452.1-30X3.1	Oil seal	30X3.1	1
14	D330A-21240	Washer		1
15	D330AV-21118	Handle base		1
16	GB/T78-M6X16	Screw	M6X16	2
17	D330A-21249	Handle		1
18	D330DV-21117	Handle base		1
19	GB308-6	Ball	6	1
20	GB2089-6X26X1	Spring	6X26X1	1
21	GB/T77-M8X8	Screw	M8X8	1
22		Position sign plate		1
23	GB/T818-M4X6	Screw	M4X6	2
24	GB7271.3-M8	Cover	M8	2
25	D330A-21248	Handle		1
26	D330A-21120	Handle base		1
27	GB308-5	Ball		1
28	GB2089-6X26X1	Spring	5X25X0.8	1
29	GB/T77-M6X8	IScrew	M6X8	1
30	D330A-21402	Shift fork		1
31	D330A-21111	Rocker		1
32	GB/T879-4X18	Pin	4X18	1
33	D330A-21236-1	Shaft		1
34	GB/T3452.1-10X1.9	Oil seal	10X1.9	1
35	D330DV-21232	Front plug	φ 14	2
36		Copper washer	16	1

GEAR BOX

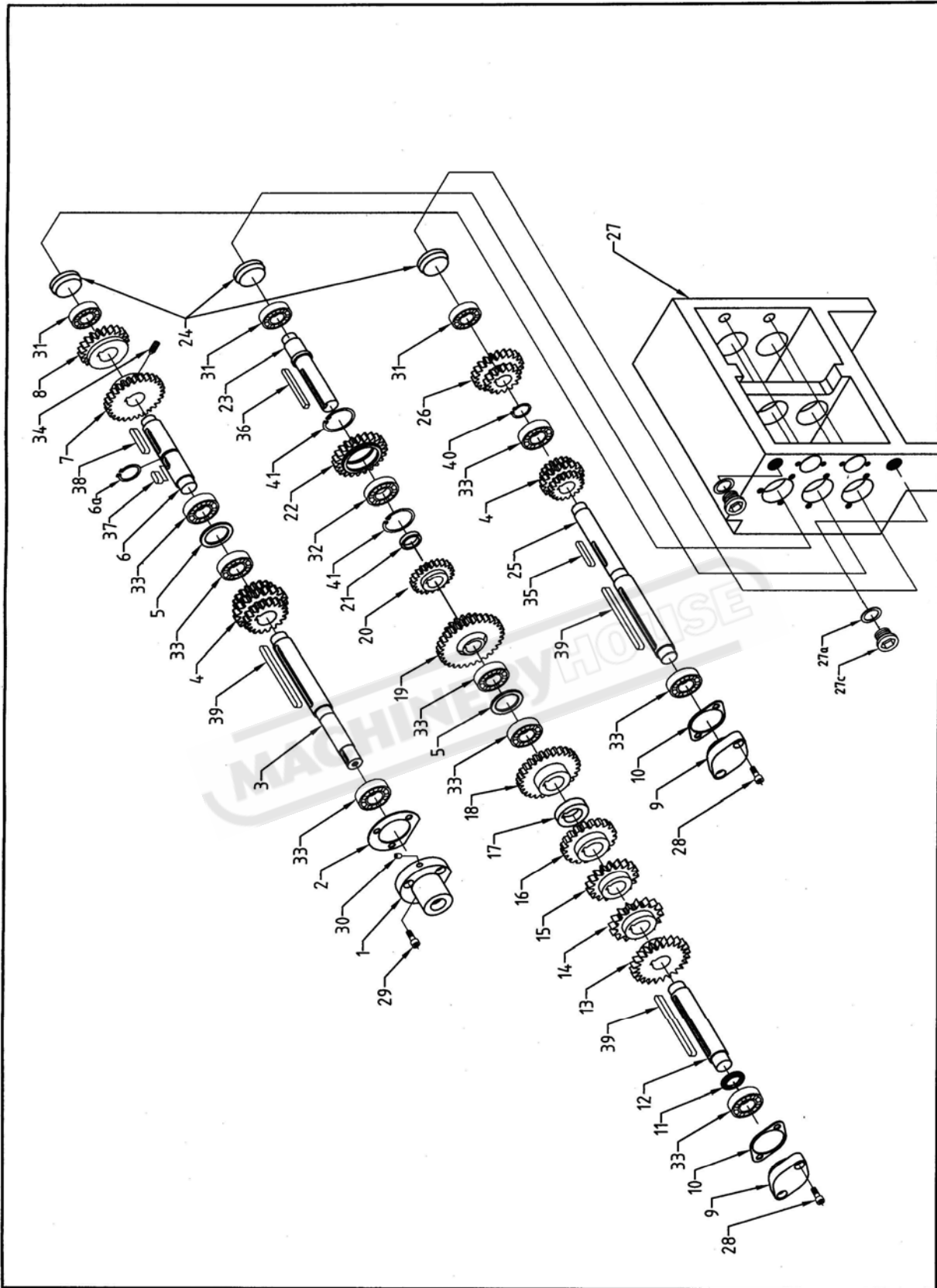

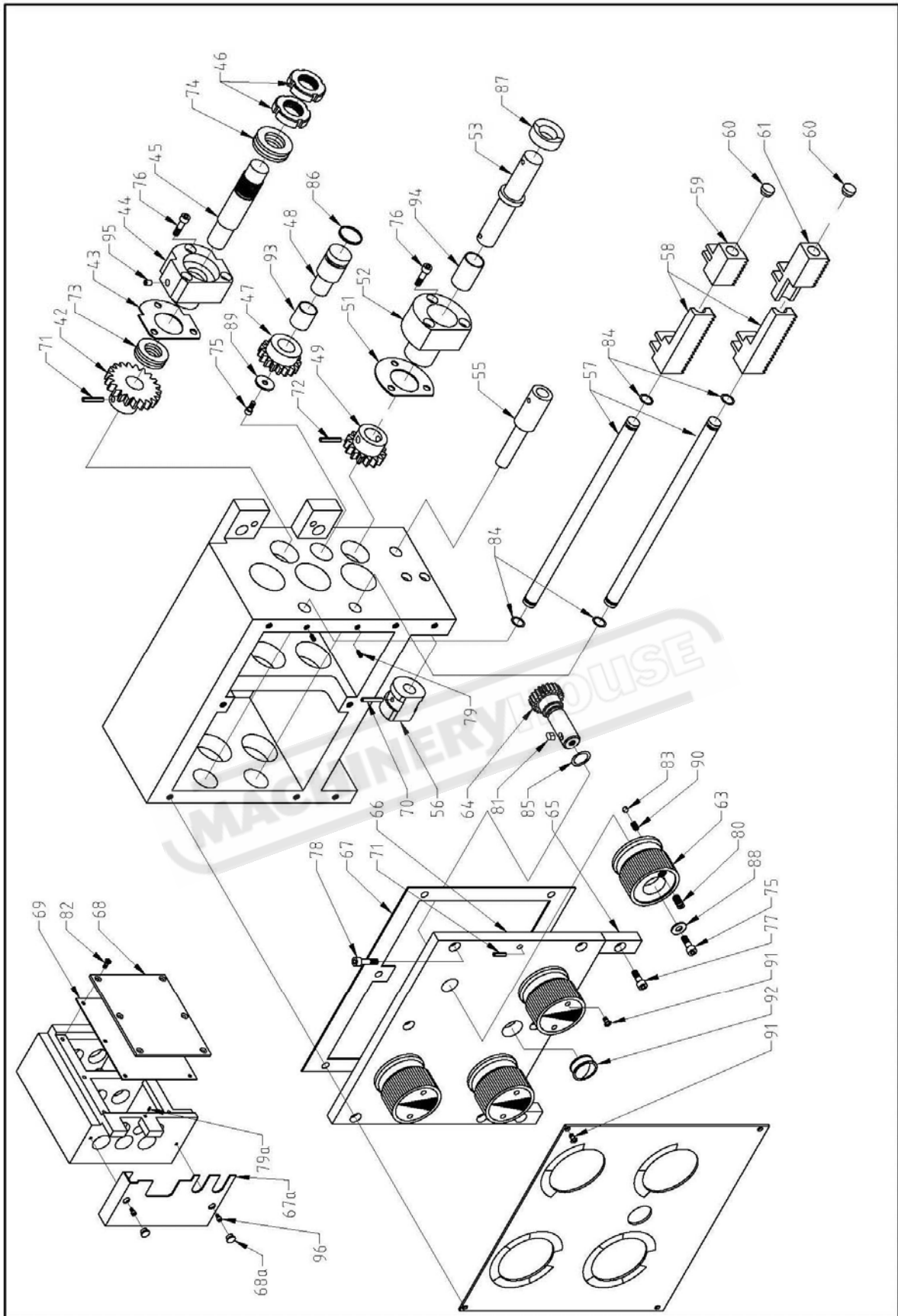

GEAR BOX

Index No.	Part No.	Description	Size	Qty.
1	D330A-3034	Cover		1
2	D330A-3035	Oil seal		1
3	D330A-3041	Shaft		1
4	D330A-3005	Gear		2
5	D330A-3066	Washer		2
6	D330A-3067	Shaft		1
6a	GB894.1-20	Circlip	20	1
7	D330A-3027	Gear		1
8	D330A-3025	Gear		2
9	D330A-3044	Cover		2
10	D330A-3046	Oil seal		2
11	D330A-3045	Washer		1
12	D330A-3033	Shaft		1
13	D330A-3029	Gear		1
14	D330A-3031	Gear		1
15	D330A-3032	Gear		1
16	D330A-3003	Gear		1
17	D330A-3030	Washer		1
18	D330A-3002	Gear		1
19	D330A-3026	Gear		1
20	D330A-3007	Gear		1
21	D330A-3008	Washer		1
22	D330A-3009	Gear		1
23	D330A-3019	Shaft		1
24	CQ6230-3017B	Cover		3
25	D330A-3004	Shaft		1
26	D330A-3006	Gear		1
27	CQ6230-3001E	Gear box		1
27a		Copper Washer	16	1
27c		Screw	M16X1.5	2
28	GB/T70-M6X12	Hex Socket Cap Screw	M6X12	4
29	GB/T70-M6X16	Hex Socket Cap Screw	M6X16	3
30	JB/T7940.4-6	Oil prot	6	1
31	GB/T276-6002	Bearing	6002	3
32	GB/T276-16003	Bearing	16003	1
33	GB/T276-6003	Bearing	6003	8
34	GB/T78-M6X8	Screw	M6X8	1
35	GB/T1096-A5X35	Key	A5X35	1
36	GB/T1096-C5X40	Key	C5X40	1
37	GB/T1096-A6X15	Key	A6X15	1
38	GB/T1096-A6X35	Key	A6X35	1
39	GB/T1096-A6X90	Key	A6X90	3
40	GB/T894.1-17	Circlip	17	1
41	GB/T893.1-35	Circlip	35	2
42	.D330A-3018	Gear		1
43	CQ6230-3068D	Oil seal		1
44	CQ6230-3084D	Cover		1
45	D330 A-3021	Shaft		1

Index No.	Part No.	Description	Size	Q t y .
46	D330A-GB812	Nut		2
47	D330A-3016	Gear		1
48	D330A-3015	Shaft		1
49	D330A-3014	Gear		1
51	CQ6230-3086D	Oil Seal		1
52	CQ6230-3022F	Cover		1
53	CQ6230-3013D	Shaft		1
55	CQ6230-3011D	Shaft		1
56	D330A-3012	Position Piec		1
57	CQ6230-3089A	Shaft		2
58	CQ6230-3049C	Gear Rack		2
59	CQ6230-3062C	Gear Rack		1
60	CQ6230-3091B	Cover		2
61	CQ6230-3050C	Gear Rack		1
63	CQ6230-3054F	Boss		4
64	CQ6230-3088	Gear		4
65	CQ6230-3061B	Washer		2
66	CQ6230-3059E	Cover		1
67	CQ6230-3087D	Oil seal		1
67a	D330A-3001A	Cover		1
68	D330A-3042	Cover		1
68a		Cover	φ 13	2
69	D330A-3070	Oil seal		1
70	GB/T879-4X28	Pin	4X28	1
71	GB/T879-5X26	Pin	5X26	2
72	GB/T879-5X28	Pin	5X28	2
73	GB/T301-51103	Bearing		1
74	GB/T301-51104	Bearing		1
75	GB/T70- M6X12	Hex Socket Cap Screw	M6X12	5
76	GB/T70- M6X25	Hex Socket Cap Screw	M6X25	6
77	GB/T70- M8X16	Hex Socket Cap Screw	M8X16	2
78	GB/T70- M8X20	Hex Socket Cap Screw	M8X20	6
79	GB/T78- M4X8	Screw	M4X8	2
79a	GB/T78- M5X8	Screw	M5X8	1
80	GB/T77- M8X6...	Screw	M8X6	4
81	GB/T1096-A5X8	Key	A5X8	4
82	GB/T819-M6X10	Screw	M6X10	6
83	GB308-89-6	Ball	6	4
84	GB/T3452.1-12X1.8	Oil seal	12X1.8	4
85	GB/T3452.1-16X2.4	Oil seal	16X2.4	4
86	GB/T3452.1-22X2.4	Oil seal	22X2.4	1
87	GB/T9877.1-18X30X10	Oil seal	18X30X10	1
88	GB/T97.1-6	Washer	6	4
89	GB/T96-6	Washer	6	1
90	GB2089-6X18X0.8	Spring	6X18X0.8	4
91	GB/T818-M4X6	Screw	M4X6	12
92		Oil seal	M22X1.5	1
93		Copper Washer	16X18X20	1
94		Copper Washer	17X19X30	1
95	JB/T7940.4-6	Oil port	6	1
96	GB/T70-M5X8	Hex Socket Cap Screw	M5X8	2

APRON

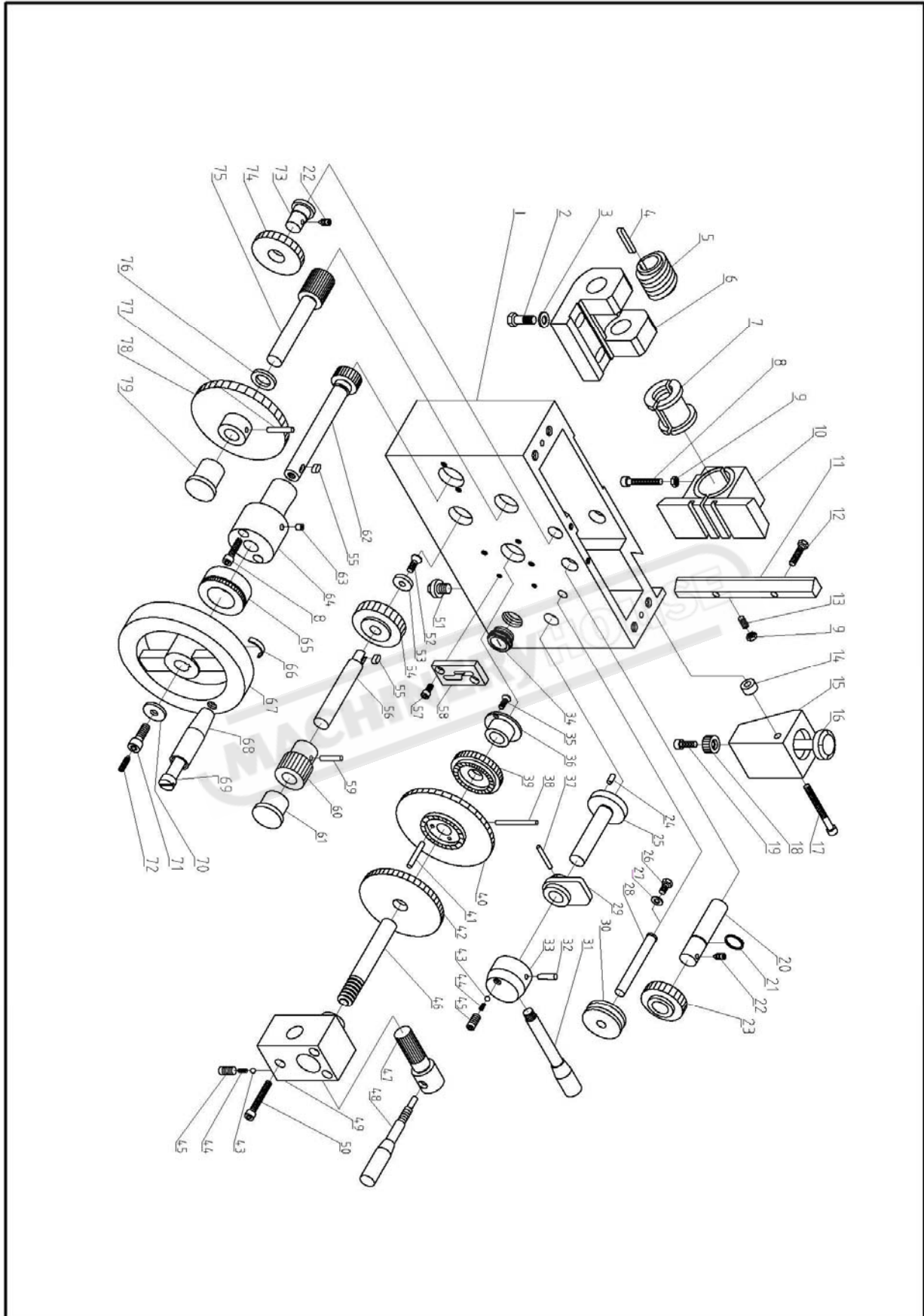

APRON

Index No	Part No	Description	Size	Qty
1	CQ6230-4001	Apron Casting		1
2	GB/T5782-M8X30	Cap Screw	M8X30	2
3	GB/T97.1-8	Washer	8	2
4	GB/T1096-5X36	Key	5X36	1
5	CQ6230-4008	Worm		1
6	CQ6230-4009	Bracket		1
7	CQ6230-4003	Half Nut Half Nut		1
8	GB/T70-M6X40	Cap Screw	M6X40	3
9	GB/T6175-M6	Nut	M6	3
10	CQ6230-4002	Bracket		1
11	CQ6230-4022	Gib		1
12	GB/T5782-M6X25	Cap Screw	M6X25	2
13	GB/T77-M6X15	Screw	M6X15	2
14	CQ6230-4007	Washer		1
15	CQ6230-4005	Bracket		1
16	CQ6230-4006	Shaft		1
17	GB/T70-M6X60	Cap Screw	M6X60	1
18	CQ6230-4004	Gear		1
19	GB/T70-M6X15	Cap Screw	M6X15	1
20	CQ6230-4046	Shaft		1
21	GB/T894.1-18	Circlip	18	1
22	GB/T78-M6X6	Screw	M6X6	2
23	CQ6230-4035	Gear		1
24	GB/T119-5X10	Pin	5X10	2
25	CQ6230-4023	Shaft		1
26	GB/T5782-M6X10	Cap Screw	M6X10	1
27	GB/T97.1-6	Washer	6	1
28	CQ6230-4024	Shaft		1
29	CQ6230-4021	Locating Block		1
30	CQ6230-4025	Fork		1
31	CQ6230-4044	Lever		1
32	GB/T117-5X40	Taper Pin	5X40	1
33	CQ6230-4045	Lever Hand		1
34	JB/T7941.2-M22X1.5	Oil seal	M22X1.5	1
35	GB/T65-M5X12	Screw	M5X12	2
36	CQ6230-4016	Washer		1
37	GB/T879-4X30	Pin	4X30	1
38	GB/T879-4X50	Pin	4X50	1
39	CQ6230-4014	Gear		1
40	CQ6230-4013	Gear		1

Index No	Part No	Description	Size	Qty
41	GB/T119-5X33	Pin	5X33	3
42	CQ6230-4013	Gear		1
43	GB308---6	Steel Ball	6	2
44	CQ6123-14-01	Sping		2
45	GB/T77-M8X8	Screw	M8X8	2
46	CQ6230-4015	Shaft		1
47	CQ6230-4042	Gear		1
48	CQ6230-4041	Lever		1
49	CQ6230-4039	Bracket		1
50	GB/T70-M6X45	Cap Screw	M6X45	3
51		Bolt	M10X1	1
52	GB/T819-M6X12	Screw	M6X12	1
53	CQ6230-4048	Washer		1
54	CQ6230-4017	Gear		1
55	GB/T1096-5X10	Key	5X10	2
56	CQ6230-4018	Shaft		1
57	GB/T70-M5X10	Cap Screw	M5X10	2
58	CQ6230-4043	Locating Block Shaft		1
59	GB/T879-5X25	Pin	5X25	1
60	CQ6230-4019	Gear		1
61	CQ6230-4020	Washer		1
62	CQ6230-4030	Shaft		1
63	GB/T7940.4—6	Oil Port	6	1
64	CQ6230-4031	Bracket		1
65	CQ6230-4036	Graduated Dial		1
66	CQ6230-4037	Cursor		1
67	CQ6230-4034	Hand Wheel		1
68	CQ6230-4032	Handle		1
69	CQ6230-4033	Handle screw		1
70	CQ6230-4038A	Washer		1
71	CQ6230-4047	Screw		1
72	GB/T79-5X30	Screw	5X30	1
73	CQ6230-4011	Shaft		1
74	CQ6230-4010	Gear		1
75	CQ6230-4028	Shaft		1
76	CQ6230-4027	Washer		1
77	GB/T879-5X30	Pin	5X30	1
78	CQ6230-4029	Gear		1
79	CQ6230-4026	Washer		1

COMPOUND REST

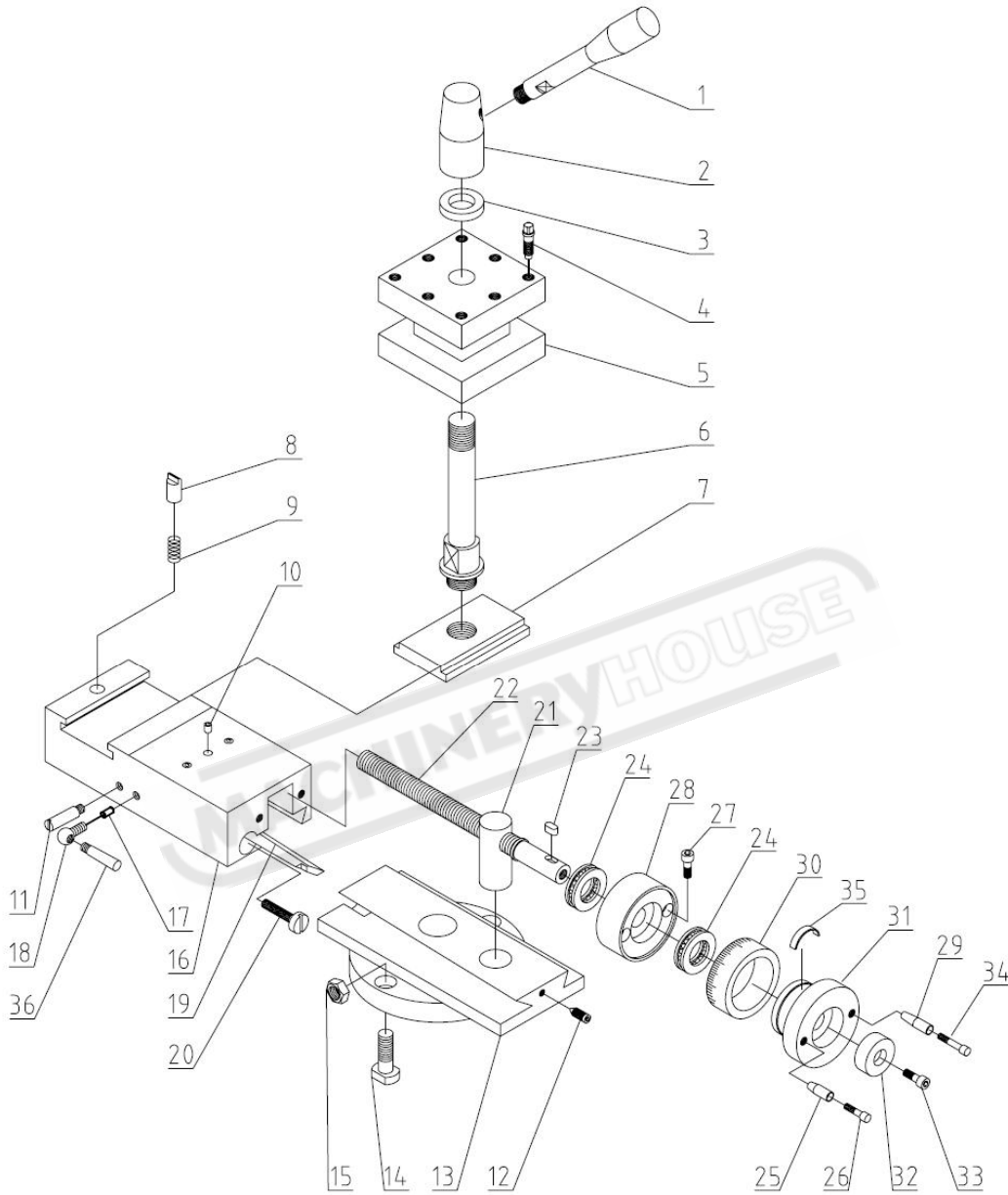

COMPOUND REST

Index No	Part No	Description	Size	Qty
1	CQ6230-5010	Handle		1
2	CQ6230-5009	Boss		1
3	CQ6230-5008	Collar		1
4	GB/T83-M10×45	Screw	M10×45	8
5	CQ6230-5005	Tool Post		1
6	CQ6230-5006	Shaft		1
7	CQ6230-5003	Nut		1
8	CQ6230-5004	Pin		1
9	GB2089-1.2×6×8	Spring	1.2×6×8	1
10	JB/T7940.4-6	Oil cup	6	3
11	D330A-S2003	Shaft		1
12	GB/T78-M6×16	Screw	M6×16	1
13	CQ6230-5001	Compound		1
14	D330A-51203	"T" Screw		2
15	GB/T6175-M10	Nut	M10	2
16	CQ6230-5002	Compound		1
17	CQ6230-5024	Pin		1
18	D330A-S2001	Screw		1
19	CQ6230-5023	Gib		1
20	CQ6230-5021	Screw		2
21	CQ6230-5012	Nut		1
22	CQ6230-5011	Guide Screw		1
23	GB/T1096-A4×8	Key	A4×8	1
24	GB/T301-51101	Bearing		2
25		Collar		1
26		Bolt		1
27	GB/T70-M6×25	Hex Socket Cap Screw	M6×25	2
28	CQ6230-5013	Bracket		1
29		Collar		1
30	CQ6230-5014	Index Ring		1
31		Hand Wheel		1
32		Washer		1
33	GB/T70-M6×12	Hex Socket Cap Screw	M6×12	1
34		Bolt		1
35	CQ6230-4037	Leaf spring		1
36	D330A-S2002	Bolt		1

SADDLE

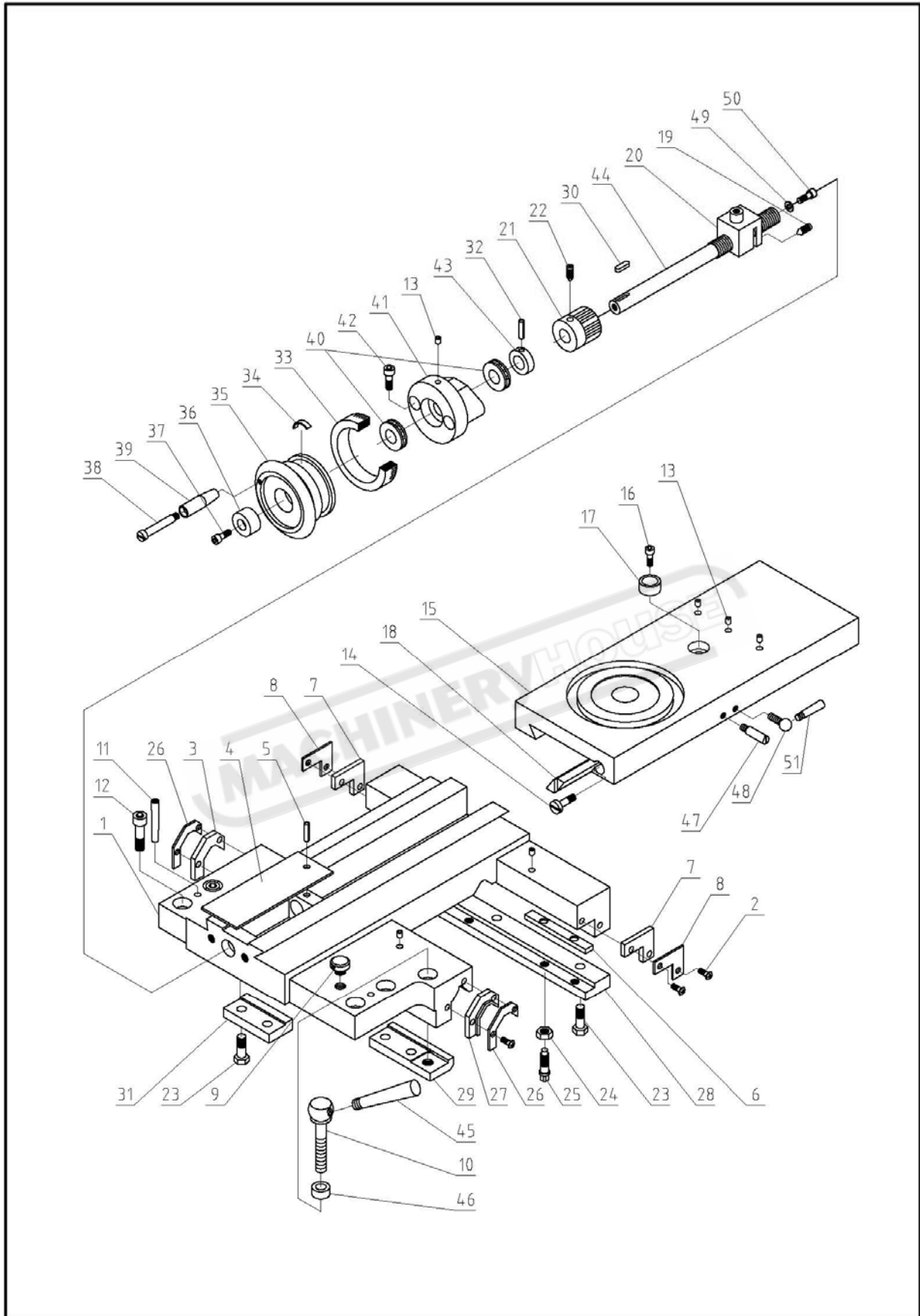

SADDLE

Index No	Part No	Description	Size	Qty
1	D330A-51101	Saddle		1
2	GB818-M5X12	Screw	M5X12	8
3	D330A-51301	Wipper		1
4	D330A-51211	Cover		1
5	GB/T879-3X10	Pin	3X10	1
6	D330A-51216	Press plate		2
7	D330A-51303	Press plate		2
8	D330A-51204	Wipper		2
9	D330A-51215	Screw		1
10	D330A-S1001	Screw		1
11	GB/T118-6X45	Taper Pin	6X45	2
12	GB/T70-M10×30	Hex Socket Cap Screw	M10×30	4
13	JB/T7940.4-6	Oil cup	6	6
14	D330A-51214	Screw		2
15	D330A-51102	Tool post		1
16	GB/T70-M6×12	Hex Socket Cap Screw	M6×12	1
17	D330A-51201	Bushing		1
18	D330A-51212	Gib		1
19	GB/T78-M4×12	Screw	M4×12	2
20	D330A-51401	Nut		1
21	D330A-51202	Gear		1
22	GB/T78-M6×8	Screw	M6×8	1
23	GB/T5782-M8×25	Screw	M8×25	7
24	GB/T6175-M8	Nut	M8	4
25	GB/T83-M8×25	Screw	M8×25	4
26	D330A-51205	Press plate		2
27	D330A-51302	Wipper		1
28	D330A-51104	Press Plate		1
29	D330A-51105	Press Plate		1
30	GB/T1096-5×20	Key	5×20	1
31	D330A-51103	Press Plate		1
32	GB/T879-4X25	Pin	4X25	1
33	D330A-51208	Index Ring		1
34	CQ6230-4037	Leaf spring		1
35	D330A-51207	Hand wheel		1
36	D330A-51207-1	Washer		1
37	GB/T70-M6×16	Hex Socket Cap Screw	M6×16	1
38	JD10-06027A	Handle screw		1
39	JD10-06027	Handle		1
40	GB/T301-51102	Bearing	51102	2
41	D330A-51106	Bracket		1
42	GB/T70-M8×30	Hex Socket Cap Screw	M8×30	2
43	D330A-51210	Washer		1
44	D330A-51206	Guide Screw		1
45	D330A-S1002	Handle		1
46	D330A-S1003	Lock Handle		1
47	D330A-S2003	Screw		1
48	D330A-S2001	Screw		1
49	GB/T97.1-5	Washer	5	1
50	GB/T70-M5×12	Hex Socket Cap Screw	M5×12	1
51	D330A-S2002	Handle		1

TAILSTOCK

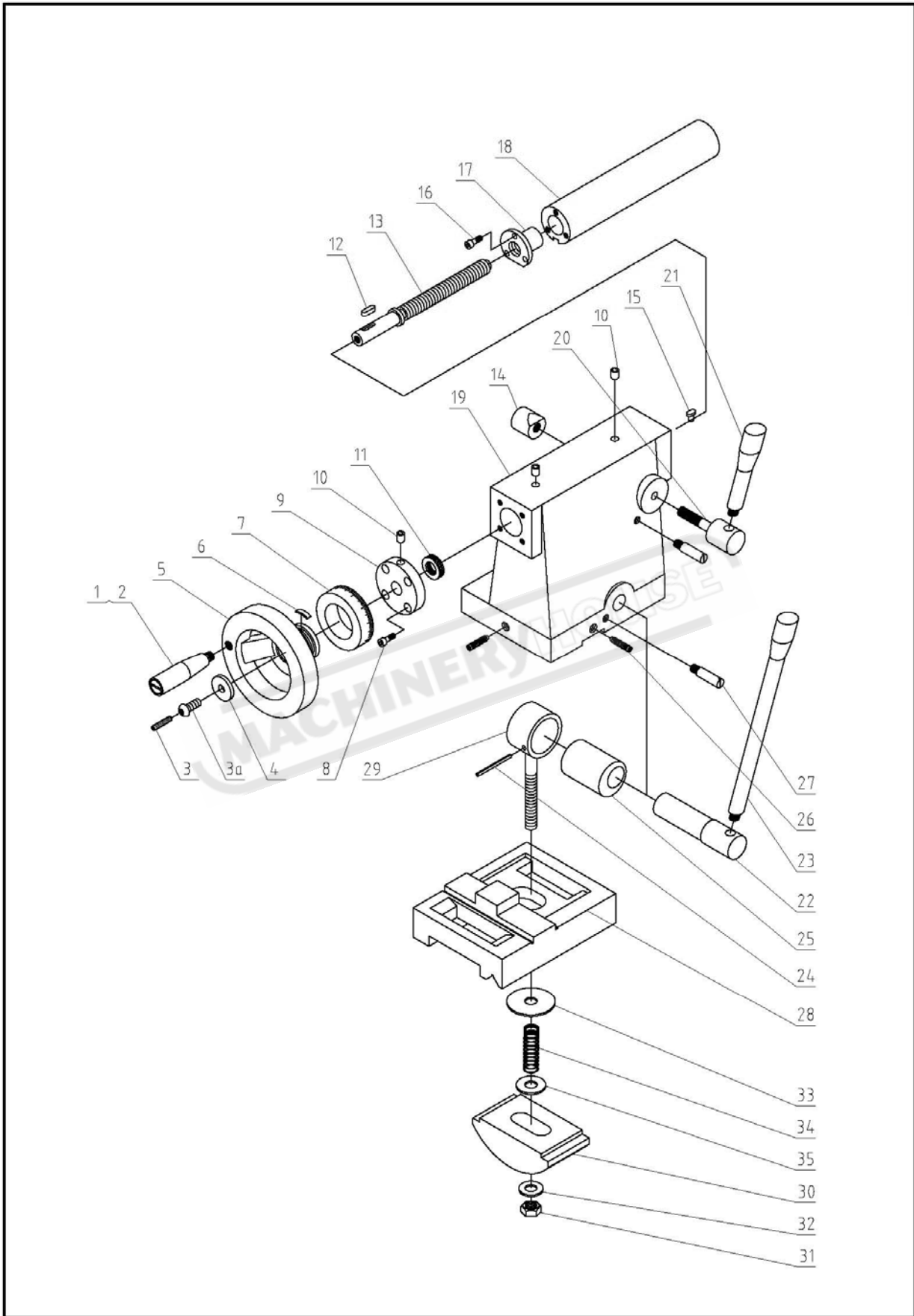

TAILSTOCK

Index No	Part No	Description	Size	Qty
1	CQ6230-4033	Handle		1
2	CQ6230-4032	Lever		1
3	GB/T77-M5X25	Screw	M5X25	1
3a	D330A-6044	Adjusting screw		1
4	D330A-6045	Washer		1
5	D330A-6005	Hand Wheel		1
6	CQ6230-4037	Leaf Spring		1
7	D330A-6010	Index Ring		1
8	GB/T70-M6X16	Hex Socket Cap Screw	M6X16	4
9	D330A-6011	Bracket		1
10	JB/T7940.4-8	Oil Cup	8	3
11	GB/T301-51102	Bearing		1
12	GB/T1096-A4X15	Key	A4X15	1
13	D330A-6006	Guide Screw		1
14	D330A-6023	Lock Nut		1
15	D330A-6015	Key		1
16	GB/T70-M4×12	Hex Socket Cap Screw	M4×12	3
17	D330A-6012	Nut		1
18	D330A-6013	Quill		1
19	D330A-6001	Tail stock		1
20	D330A-6022	Lock screw		1
21	D330A-6021	Handle		1
22	D330A-6017	Shaft		1
23	D330A-6004	Handle		1
24	GB/T119-5×30	Pin	5×30	1
25	D330A-6018	Collar		1
26	GB/T79-M10×50	Screw	M10×50	3
27	D330A-6003	Screw		2
28	D330A-6002	Base		1
29	D330A-6019	Shaft		1
30	D330A-6020	Base Shoe Black		1
31	GB/T6175-M12	Nut	M12	1
32	GB/T97.1-12	Washer		1
33	D330A-6042	Washer		1
34	D330A-6041	Spring		1
35	D330A-6043	Washer		1

CHANGE GEAR

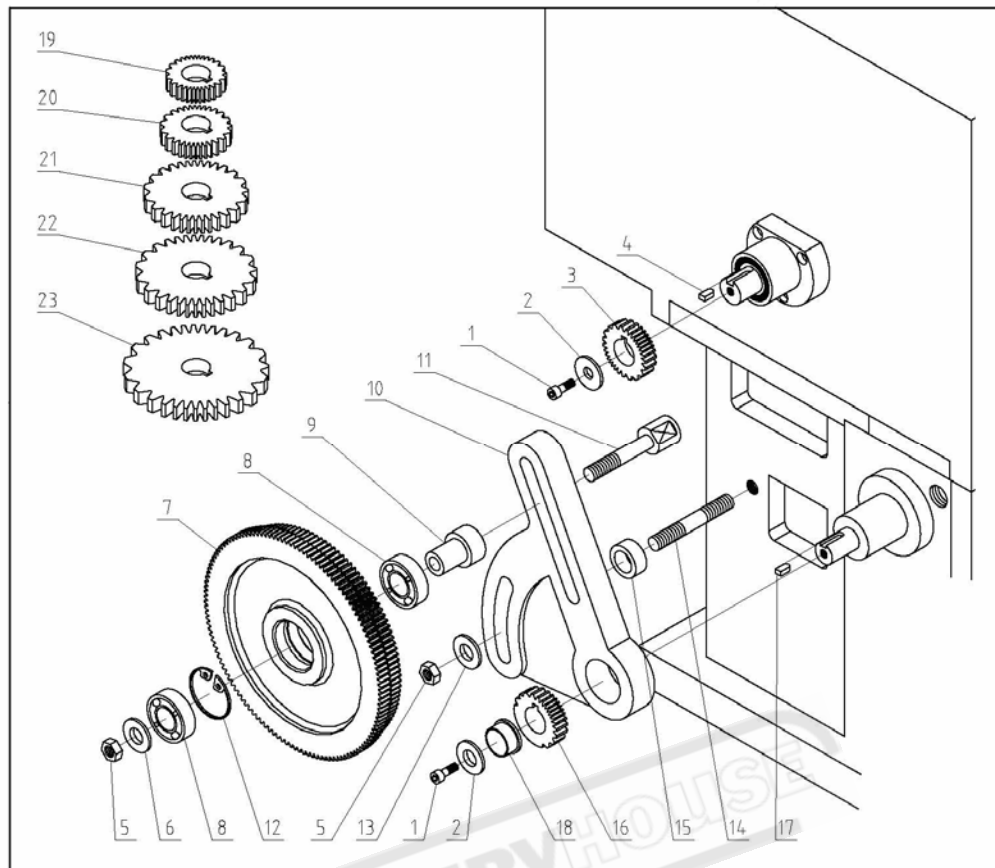

Index No.	Part No.	Description	Size	Q t y .
1	GB/T70-M6X12	Hex Socket Cap Screw	M6X12	2
2	GB/T96-6	Washer	6	2
3	D330A-91202	Gear	24T	1
4	GB/T1096-A5X8	Key	A5X8	1
5	GB/T6175-M10	Nut	M10	2
6	GB/T97.1-10	Washer	10	1
7	D330A-91208	Gear	120/127T	1
8	GB/T276-6003	Bearing		2
9	D330A-91209	Collar		1
10	D330A-91101	Quadrant		1
11	D330A-91210	Screw		1
12	GB/T893.1-35	Circlip	35	1
13	GB/T97.1-10	Washer	10	1
14	GB/T901-M10X60	Screw	M10X60	1
15	D330A-91212	Washer		1
16	D330A-91206	Gear	48T	1
17	GB/T1096-A5X8	Key	A5X8	1
18	D330A-91213-1	Washer		1
19	D330A-91201	Change gear	22T	1
20	D330A-91203	Change gear	26T	1
21	D330A-91204	Change gear	38T	1
22	D330A-91205	Change gear	44T	1
23	D330A-91207	Change gear	52T	1

CONTROL SWITCH ASSEMBLY

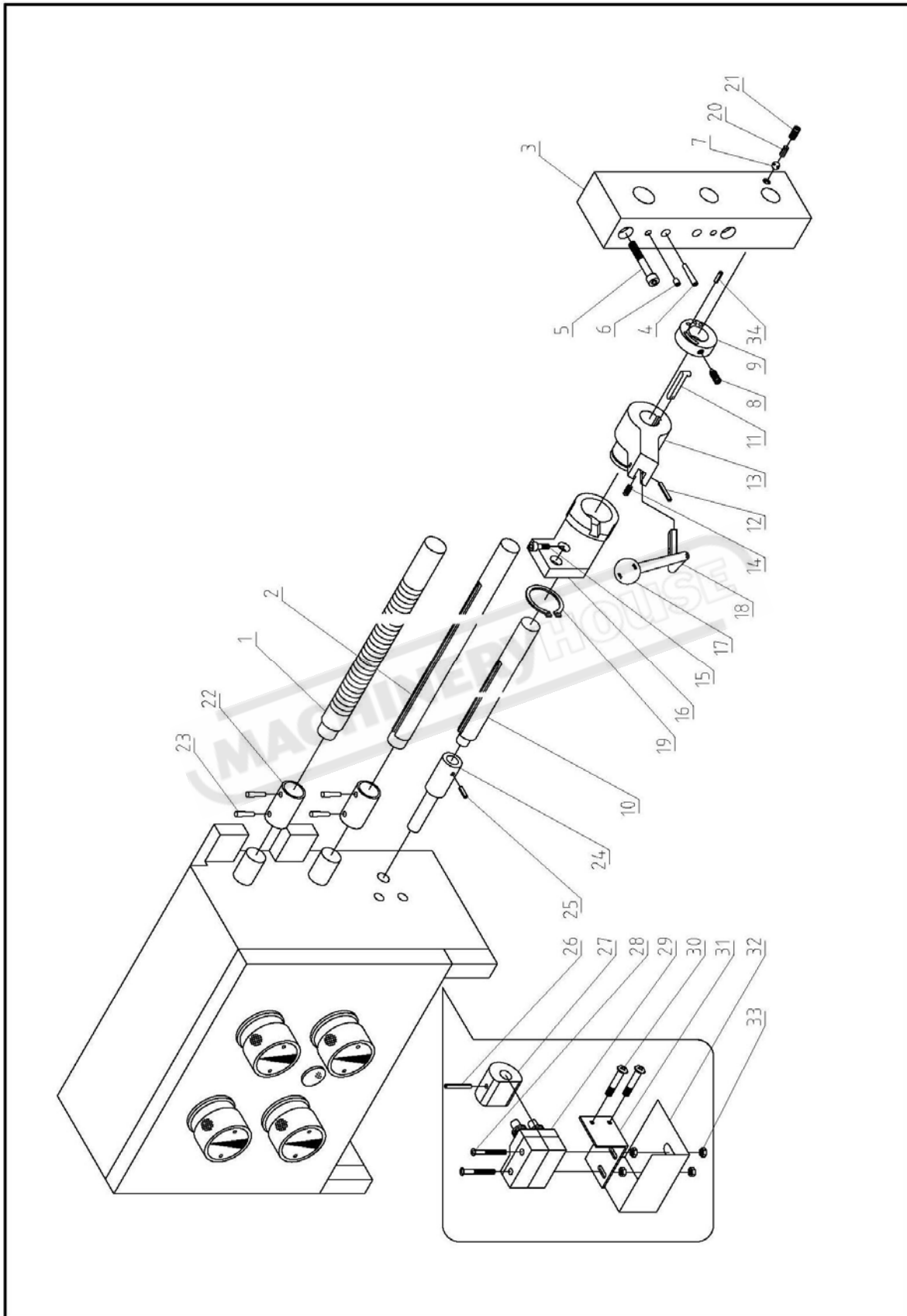

CONTROL SWITCH ASSEMBLY

Index No	Part No	Description	Size	Qty
1	D330A-11201	Guide Screw		1
2	D330A-11202	Rod		1
3	D330A-11102	Bracket		1
4	GB/T118-6X45	Taper Pin	6X45	2
5	GB/T70-M8X60	Hex Socket Cap Screw	M8X60	2
6	JB/T7940.4-6	Oil cup	6	2
7	GB308---6	Ball	6	1
8	GB/T78-M6×10	Screw	M6×10	1
9	D330A-11209-1	Bushing		1
10	D330A-11203	Feed Rod		1
11	D330A-11104-1	Key		1
12	GB/T879-4X25	Pin	4X25	1
13	D330A-11104	Bracket		1
14	GB2089-10X1X12	Spring	10X1X12	1
15	GB/T70-M6X12	Hex Socket Cap Screw	M6X12	2
16	D330A-11105	Bracket		1
17	JB/T7271.1-M10X32	Handle ball	M10X32	1
18	D330A-11206	Handle		1
19	GB/T894.1-32	Circlip	32	1
20	GB2089-1×5×30	Spring	1×5×30	1
21	GB/T77-M8X8	Screw	M8X8	1
22	D330A-11207	Washer		2
23	GB/T879-4X24	Pin	4X24	4
24	CQ6230-3011D	Shaft		1
25	GB/T879-4X20	Pin	4X20	1
26	GB/T879-4X30	Pin	4X30	1
27	D330A-3012	Position Piec		1
28	GB818-M4X50	Screw	M4X50	2
29		Switch	LXW5-11M	2
30	GB818-M4X20	Screw	M4X20	2
31	D330A-71207	Bracket		1
32	D330A-71207-1	Cover		1
33	GB/T6175-M4	Nut	M4	4
34	GB/T879-4X12	Pin	4X12	1

BED AND DRIVE ASSEMBLY

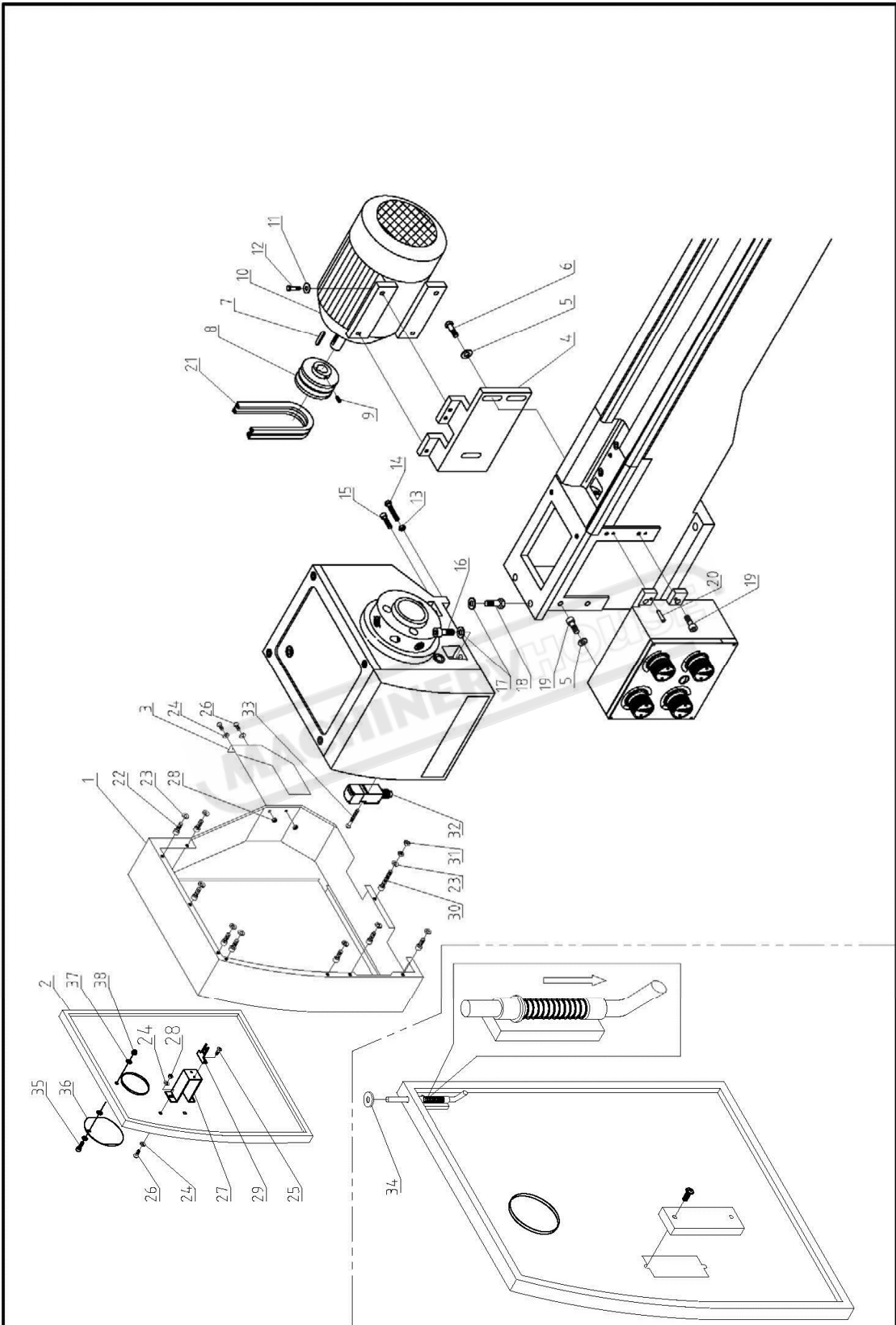

BED AND DRIVE ASSEMBLY

Index No	Part No	Description	Size	Qty
1	D330A-13401A-1	Cover		1
2	D330A-13402A-1	Cover		1
3	D330A-14220	Cover		1
4	D330A-11107	Trestle		1
5	GB/T97.1-10	Washer	10	5
6	GB/T5782-M10X30	Screw	M10X30	3
7	GB/T1096-8X35	Key	8X35	1
8	D330A-11106	Pulley		1
9	GB/T78-M6X8	Screw	M6X8	1
10		Motor		1
11	GB/T97.1-8	Washer	8	4
12	GB/T5782-M8X25	Screw	M8X25	4
13	GB/T6175-M8	Nut	M8	2
14	GB/T5782-M8X45	Screw	M8X45	2
15	GB/T70-M8X30	Hex Socket Cap Screw	M8X30	2
16	GB/T70-M12X35	Hex Socket Cap Screw	M12X35	2
17	GB/T97.1-12	Washer	12	4
18	GB/T5782-M12X30	Screw	M12X30	2
19	GB/T70-M10X30	Hex Socket Cap Screw	M10X30	4
20	GB/T117-6X30	Taper Pin	6X30	2
21		V-Belt	AV13-895	2
22	GB/T70-M5X8	Hex Socket Cap Screw	M5X8	8
23	GB/T97.1-5	Washer	5	9
24	GB/T97.1-4	Washer	4	6
25	GB818-M4X6	Screw	M4X6	2
26	GB818-M4X10	Screw	M4X10	4
27	D330A-71209	Bracket		1
28	GB/T6175-M4	Nut	M4	4
29		Switch-1	QKS8	1
30	GB/T70-M5X30	Hex Socket Cap Screw	M5X30	1
31	GB/T6175-M5	Nut	M5	2
32		Switch-2	QKS8	1
33	GB818-M4X30	Screw	M4X30	2
34		Washer		2
35	GB/T70-M6X12	Hex Socket Cap Screw	M6X12	1
36	D330D-14208B-1	Cover		1
37	GB/T97.1-6	Washer	6	3
38		Nut	M6	1

STAND/ COOLANT PUMP/LAMP

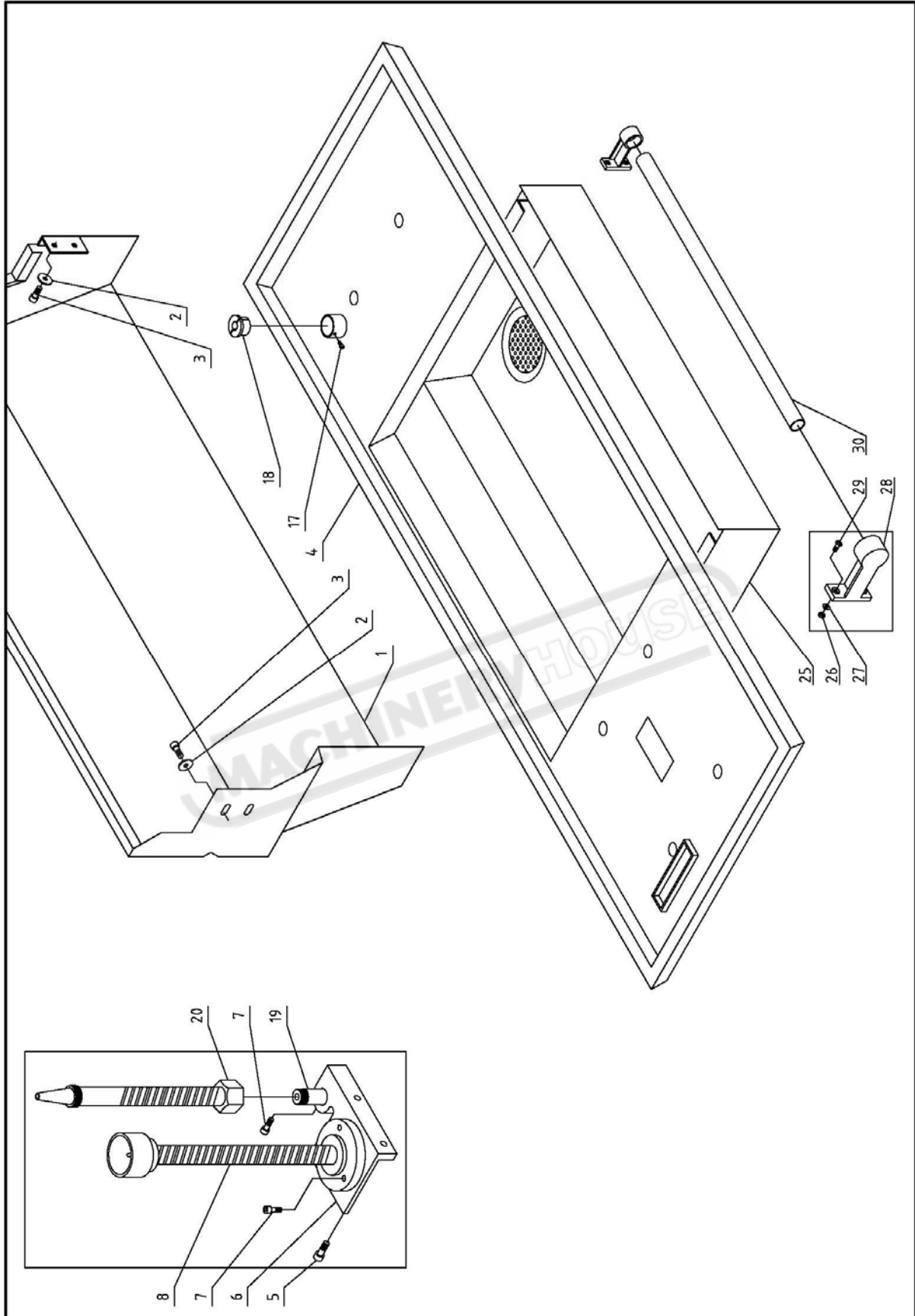

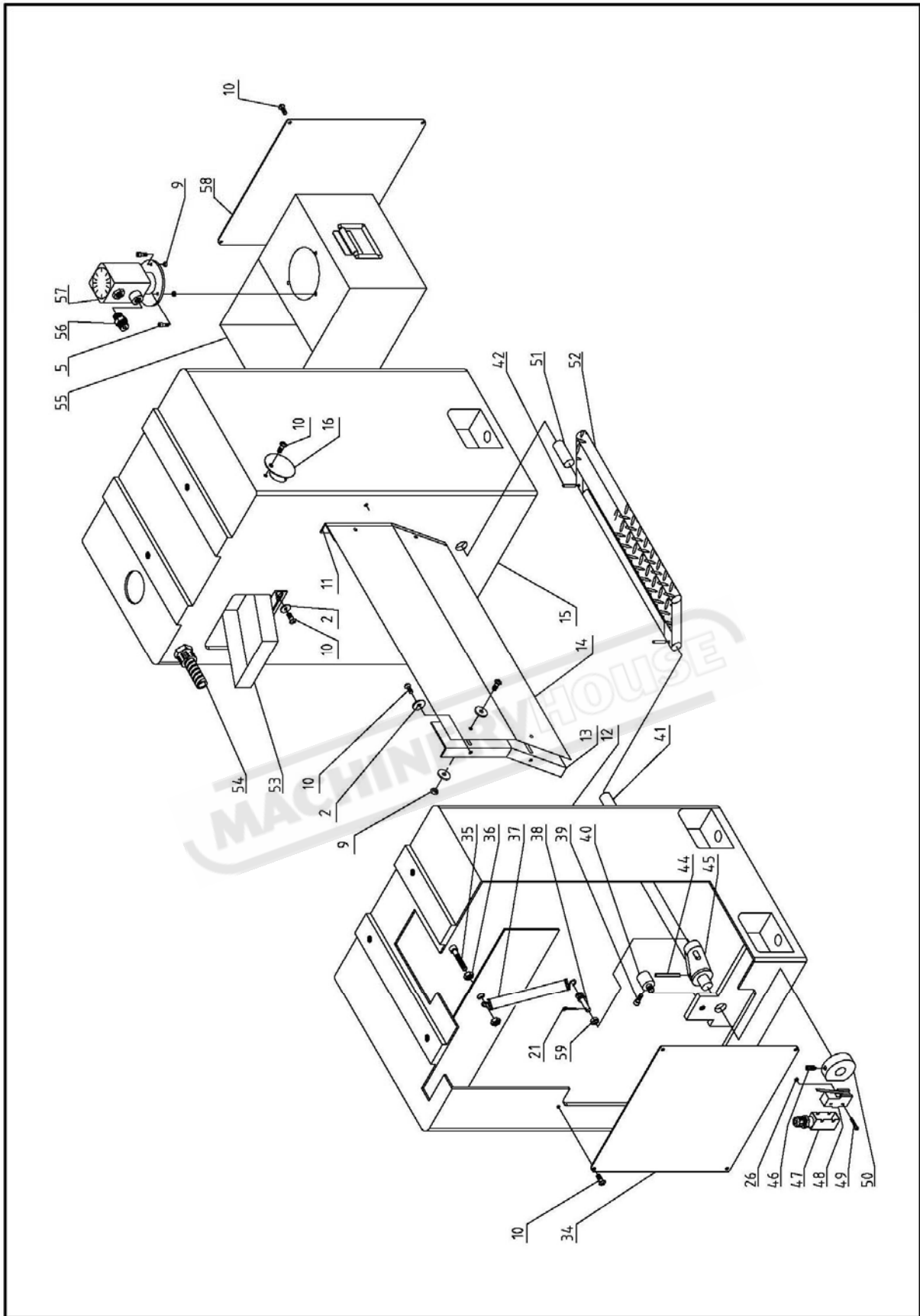

STAND/ COOLANT PUMP/LAMP

Index No	Part No	Description	Size	Qty
1	D330A-14205A-1	Chip guard		1
2	GB/T97.1-6	Washer	6	18
3	GB/T70-M6X10	Hex Socket Cap Screw	M6X10	4
4	D330A-14203A-1	Oil pan		1
5	GB/T70-M6X20	Hex Socket Cap Screw	M6X20	6
6	D330A-71206-4	Bracket		1
7	GB/T70-M5X15	Hex Socket Cap Screw	M5X15	5
8		Working lamp		1
9	GB/T6175-M6	Nut	M6	8
10	GB/T818-M6X10	Screw	M6X10	22
11	D330B-14206-1	Right bracket		1
12	D330AV-14201A	Left cabinet		1
13	D330B-14206	Left bracket		1
14	D330A-14207-1	Back plate		1
15	D330A-14202A	Right cabinet		1
16	D330D-14208B	Cover		4
17	GB/T70-M4X6	Hex Socket Cap Screw	M4X6	1
18	D330A-92206	Bracket		1
19	D330A-92202	Collar		1
20		Liquid nozzle		1
21		Pin	3X16	1
25	D330A-14204A-1	Oil pan		1
26	GB/T6175-M4	Nut	M4	6
27	GB/T97.1-4	Washer	4	4
28		Bracket		2
29	GB/T818-M4X10	Screw	M4X10	4
30		Shaft		1
34	D330A-14209A	Cover		1
35	GB/T70-M10X30	Hex Socket Cap Screw	M10X30	1
36	GB/T6175-M10	Nut	M10	2
37	D330A-11237	Drawspring		1
38	D330A-11236	Pin		1
39	GB/T70-M6X40	Hex Socket Cap Screw	M6X40	1
40	D330A-11242	Shaft		1
41	D330B-14215	Shaft		1
42	GB/T879-5X28	Pin	5X28	2
44	GB/T879-5X40	Pin	5X40	1
45	D330A-11235	Rocker		1
46	GB/T78-M6X12	Screw	M6X12	1
47		Cover		1
48		Switch	YBLXW-5/11N1	1
49	GB/T818-M4X40	Screw	M4X40	2
50	D330DV-11210	Brake dollop		1
51	D330B-14216	Shaft		1
52	D330A-14212-1	Brake pedal		1
53	D330D-14213B	Funnel		1
54		Screw Lose		2
55	D330B-14401	Water tank		1
56	D330A-92203	Connecting		1
57		Pump		1
58	D330A-14211A	Cover		1
59	D330DV-11211	Washer		1

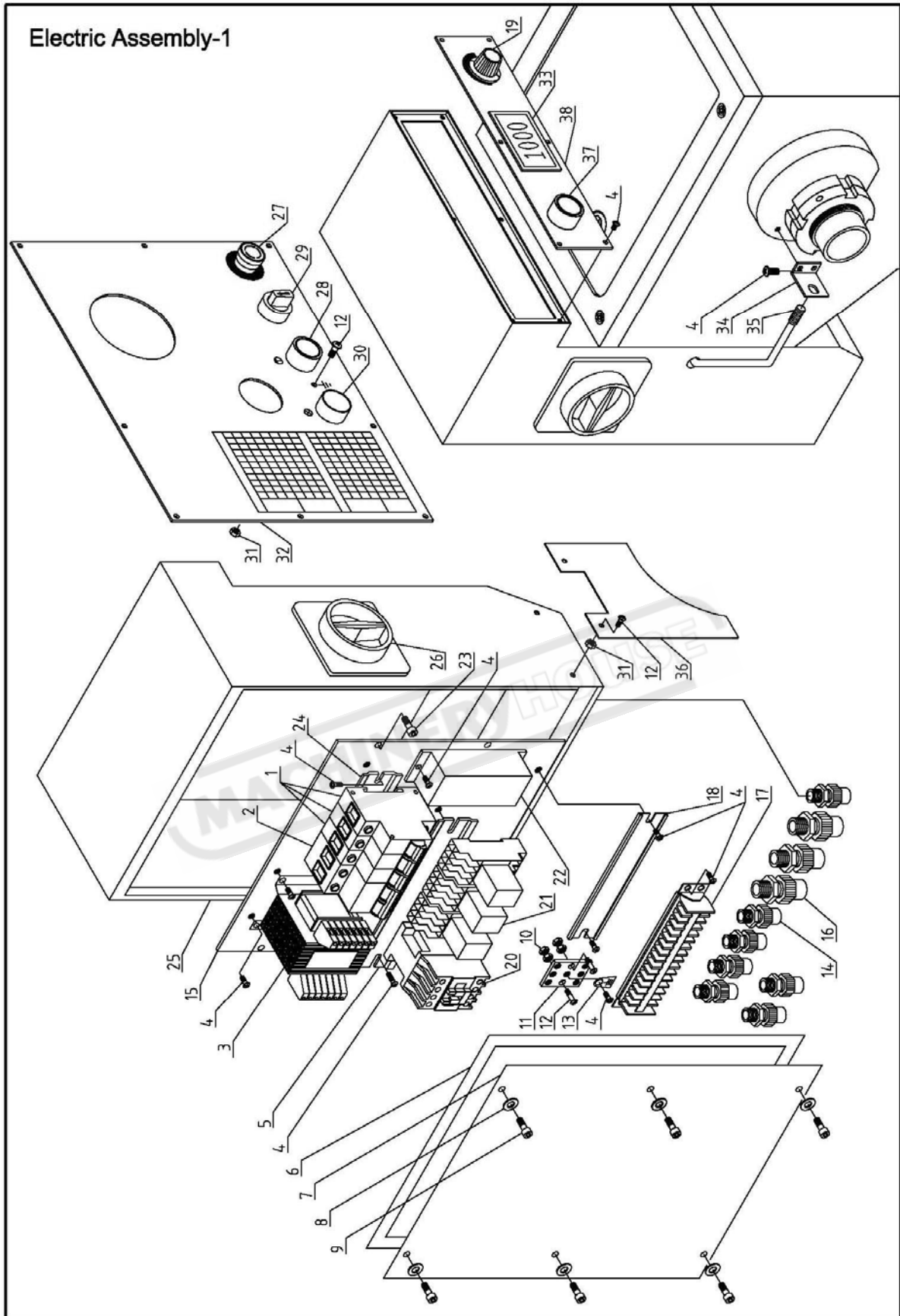

ELECTRIC ASSEMBLY-1

Index No	Part No	Description	Size	Qty
1		Protective circuit breaker	DZ47-63C3 1P	3
2		Protective circuit breaker	DZ47-63C16 2P	1
3		Transformer	JBK5-100VA-TH	1
4	GB/T818-M4X6	Screw	M4X6	24
5		Fixing Rail Clip		1
6		Rubber Cushing		4
7	D330AV-14102	Cover		1
8	GB97.1-4	Washer	4	6
9	GB/T70- M4×10	Hex Socket Cap Screw	M4×10	6
10	GB6170- M5	Nut	M5	4
11	D330A-71401	Sheet Copper		1
12	GB818-M4X12	Screw	M4X12	5
13		Earth Sign Plate		1
14		Locker Connecting	M16X1.5	7
15	D330B-14103	Base		1
16		Locker Connecting	M20X1.5	3
17		Junction Box		1
18		Fixing Rail Clip		1
19		Adjustable resistor		1
20		Intermediate relay	JZC4-40-24V	1
21		Contact Relay	HH54P	3
22		Source	5V	1
23	GB/T70- M5X12	Hex Socket Cap Screw	M5X12	4
24		Fixing Rail Clip		1
25	D330AV-14101	Electric Box		1
26		Power Switch	LW26-20	1
27		Knob	LA125H-BE102C	1
28		Fast-Stop Knob	LA125H-BE101C	1
29		Button switch	LAY3-11/2	1
30		Power Light	AD62-22D/S	1
31	GB6170- M4	Nut	M4	3
32		Plate		1
33		DRC for the spindle speed		1
34	D330DV-21255	Angle iron		1
35		Probe		1
36	D330B-14220A	CoVer		1
37		Hazard warning lamp	LAY7-24V	1
38		Plate		1

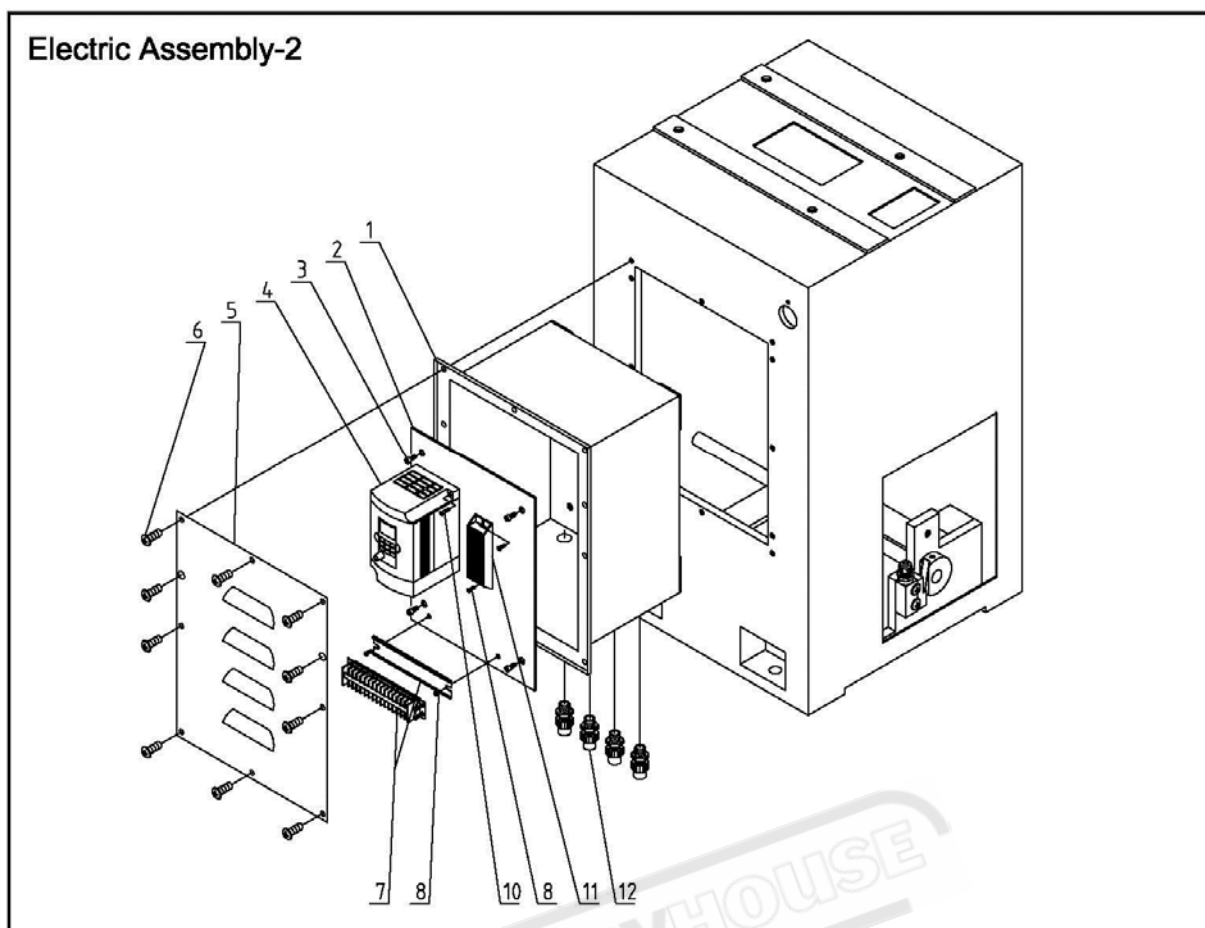

Index No	Part No	Description	Size	Qty
1	D330AV-14301	Electric Box		1
2	D330AV-14303	Base		1
3	GB/T70- M6X10	Hex Socket Cap Screw	M6×10	4
4		Inverter		1
5	D330AV-14302	Cover		1
6	GB/T818-M6X10	Screw	M6×10	10
7		Junction box	20 Seat	1
8	GB818-M4X6	Screw	M4X6	4
10	GB818-M4X12	Screw	M4X12	2
11		Braking resistor		1
12		Locker connecting	M20x1.5	4

STEADY REST

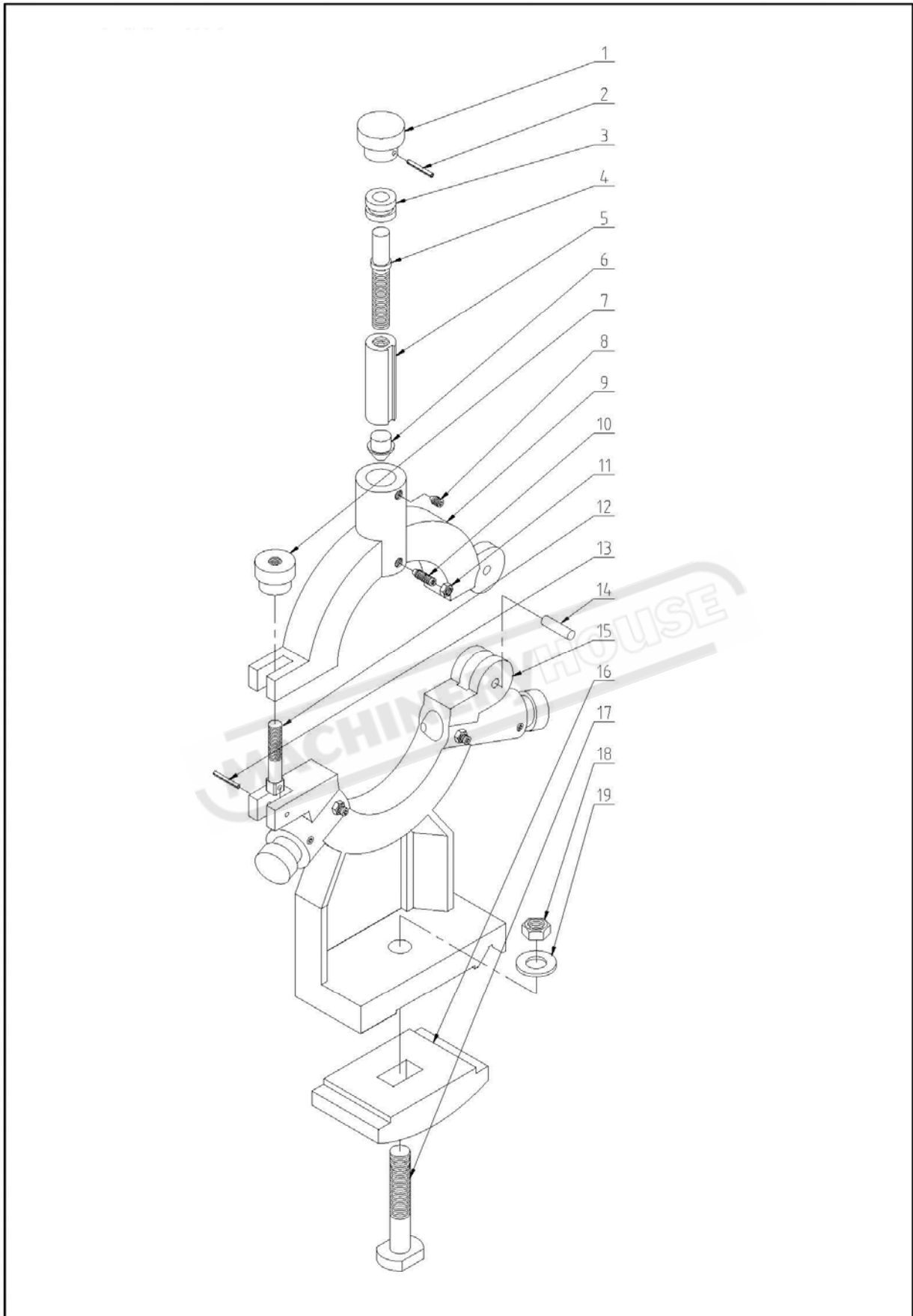

STEADY REST

Index No	Part No	Description	Size	Qty
1	D330A-8205	Knob		3
2	GB/T879-3X20	Pin	M6X8	3
3	D330A-8207	Collar		3
4	D330A-8206	Pressing Lever		3
5	D330A-8208	Pressing Collar		3
6	D330A-8209	Pressing Base		3
7	D330A-8204	Locking screw nut		1
8	GB/T78-M6X10	Screw	M6X10	3
9	D330A-8202	Upper Body		1
10	GB/T79-M6×16	Screw	M6×16	3
11	GB/T6170-M6	Nut	M6	3
12	D330A-8203	Locking lever		1
13	GB/T879-4×20	Pin	4×20	1
14	GB/T119-6X20	Pin	6X20	
15	D330A-8201	Base Body		1
16	D330A-8210	Pressing Plate		1
17	D330A-8211	"T"Screw		1
18	GB/T6170-M12	Nut	M12	1
19	GB/T97.1-12	Washer	12	1

FOLLOW REST

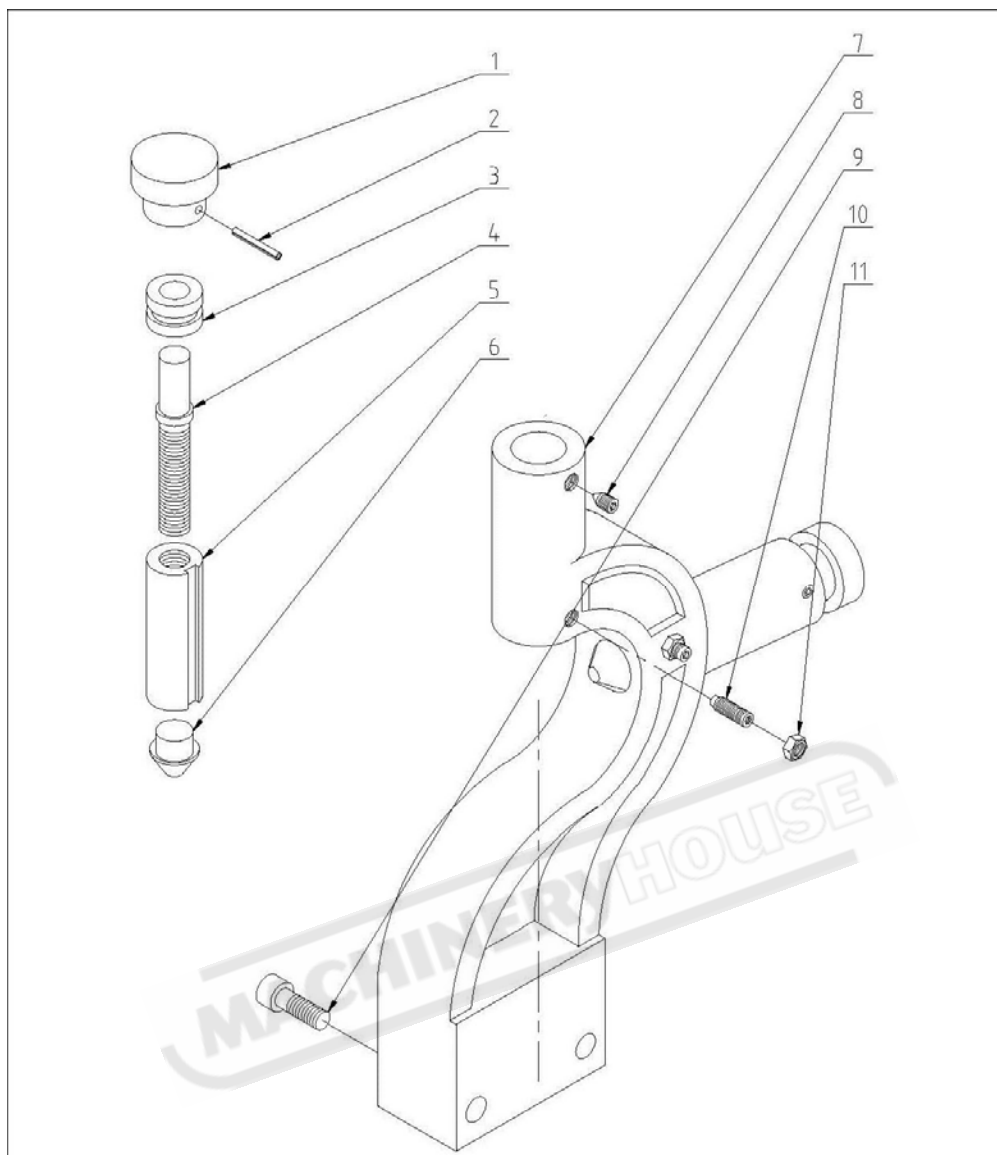

Index No	Part No	Description	Size	Qty
1	D330A-8205	Knob		2
2	GB/T879-3X20	Pin	3X20	2
3	D330A-8207	Collar		2
4	D330A-8304	Pressing Lever		2
5	D330A-8303	Pressing Collar		2
6	D330A-8209	Pressing Base		2
7	D330A-8301	Body		1
8	GB/T78-M6X10	Screw	M6X10	2
9	GB/T70-M8×40	Hex Socket Cap Screw	M8×40	2
10	GB/T79-M6×16	Screw	M6×16	2
11	GB/T6170-M6	Nut	M6	2

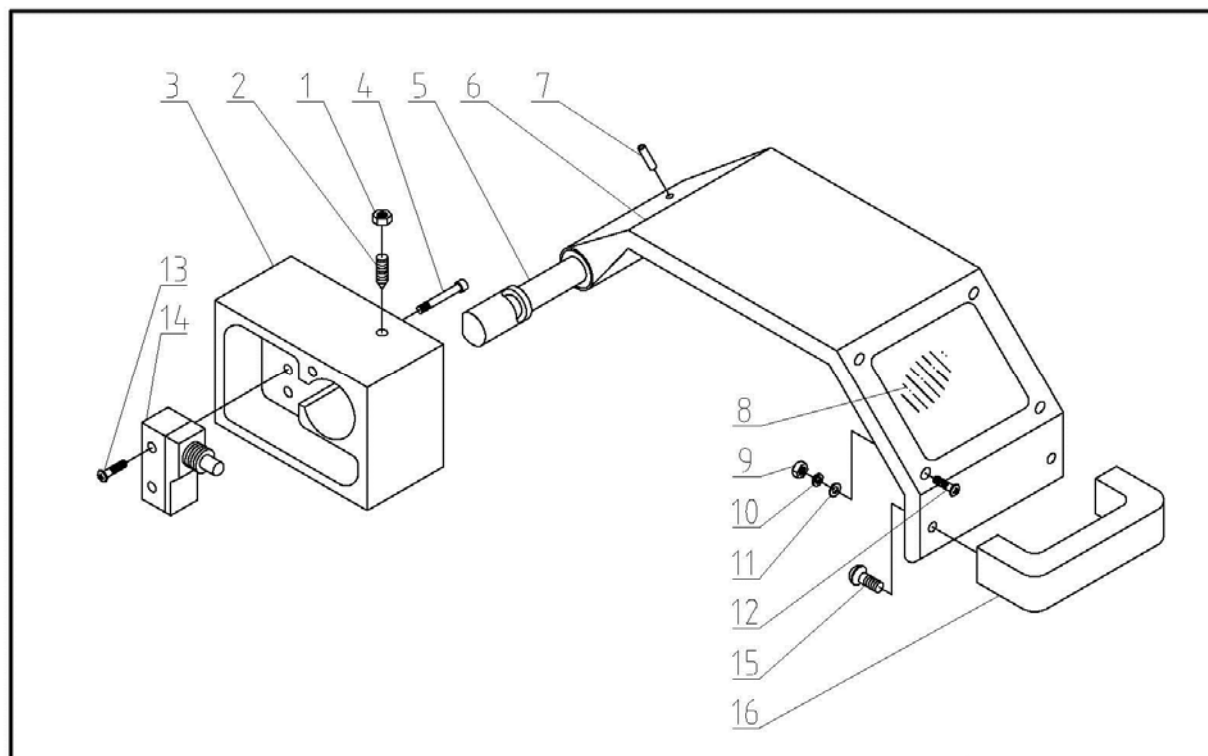
CHUCK SAFETY GUARD (Optional)

Index No	Part No	Description	Size	Qty
1	GB/T6170-M6	Nut	M6	1
2	GB/T79-M6 ×16	Screw	M6 ×16	1
3	D330A-71101	Switch box		1
4	GB/T70-M6× 45	Hex Socket Cap Screw	M6× 45	2
5	D330A-71203	Shaft		1
6	D330A-71204	Protecting Cover		1
7	GB/T879-4X25	Pin	4X25	1
8	D330A-71402	Cover		1
9	GB/T6175-M3	Nut	M3	4
10	GB/T93-3	Washer		4
11	GB/T97.1-3	Washer	3	4
12	GB/T818-M3X12	Screw	M3X12	4
13	GB/T818-M4X25	Screw	M4X25	2
14		Switch	LXW5-11M	1
15	GB/T818-M6X8	Screw	M6X8	2
16		Handle		1

LEADSCREW SAFTY GUARD (Optional)

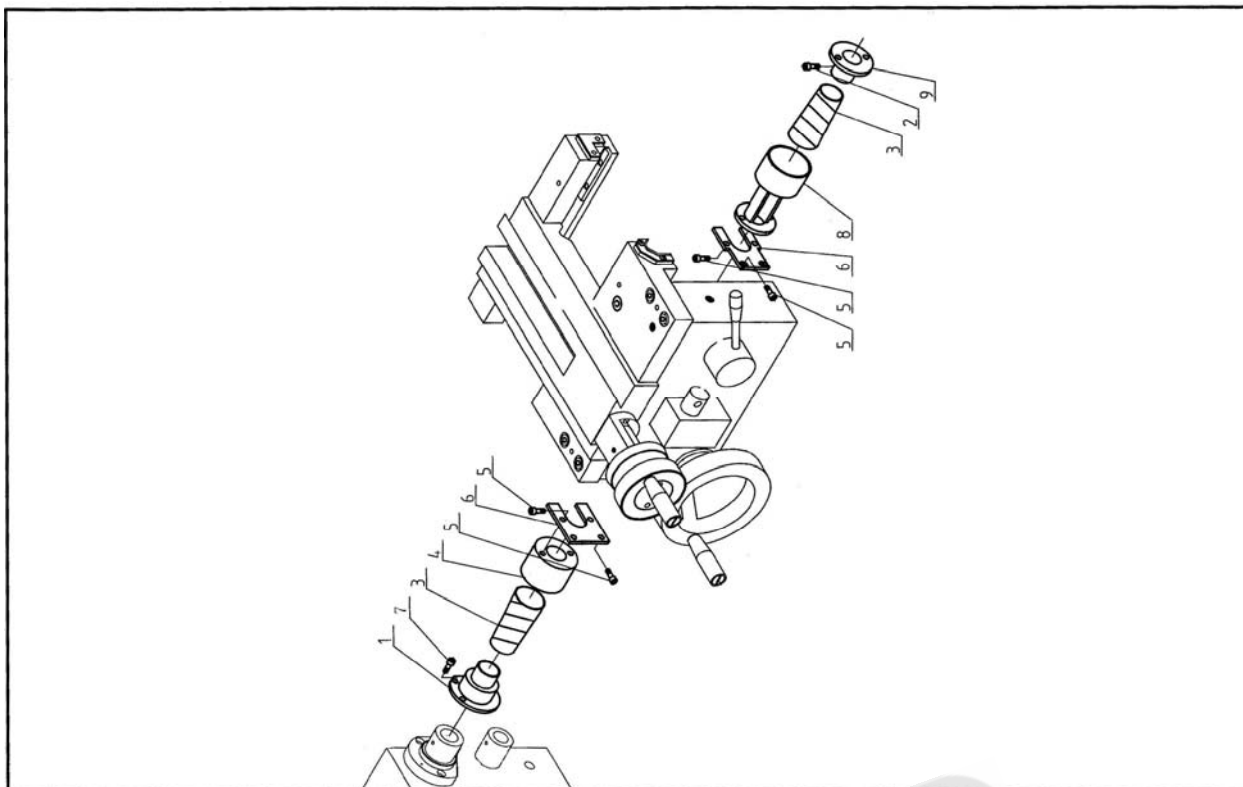

Index No	Part No	Description	Size	Qty
1	D330A-1030	Bracket		1
2	GB/T70-M5×10	Hex Socket Cap Screw	M5×10	2
3	D330A-F7001	Spring cover		2
4	D330A-1034	Left bracket		1
5	GB/T70-M6×12	Hex Socket Cap Screw	M6×12	8
6	D330A-1033	Bracket		2
7	GB/T70-M4×10	Hex Socket Cap Screw	M4×10	2
8	D330B-1029G	Bracket		1
9	D330A-1031	Bracket		1

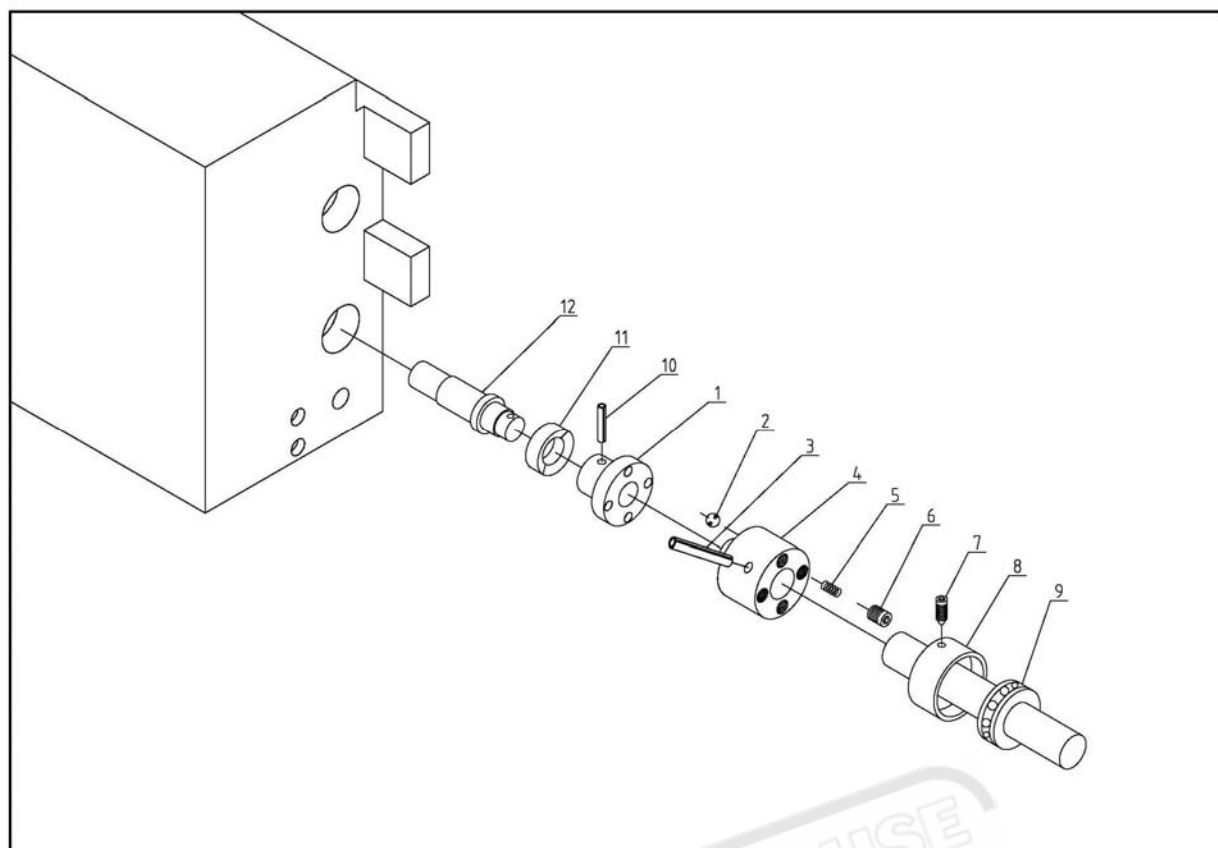
SAFTY CLUTCH FOR FEED ROD (Optional)

Index No	Part No	Description	Size	Qty
1	D330A-3013S/01A	Clutch		1
2	GB/T308-6	Steel ball	6	4
3	GB/T879-4X42	Pin	4X42	1
4	D330A-3020D-1	Clutch		1
5	GB/T1358-6X1X25	Spring	6X1X25	4
6	GB/T77-M8X8	Screw	M8X8	4
7	GB/T78-M6X10	Screw	M6X10	1
8	D330A-CS004-1	Cover		1
9	GB/T301-51104	Bearing		1
10	GB/T879-5X25	Pin	5X25	1
11	GB/T9877.1-18X30X10	Oil seal	18X30X10	1
12	CQ6230-3013D	Shaft		1

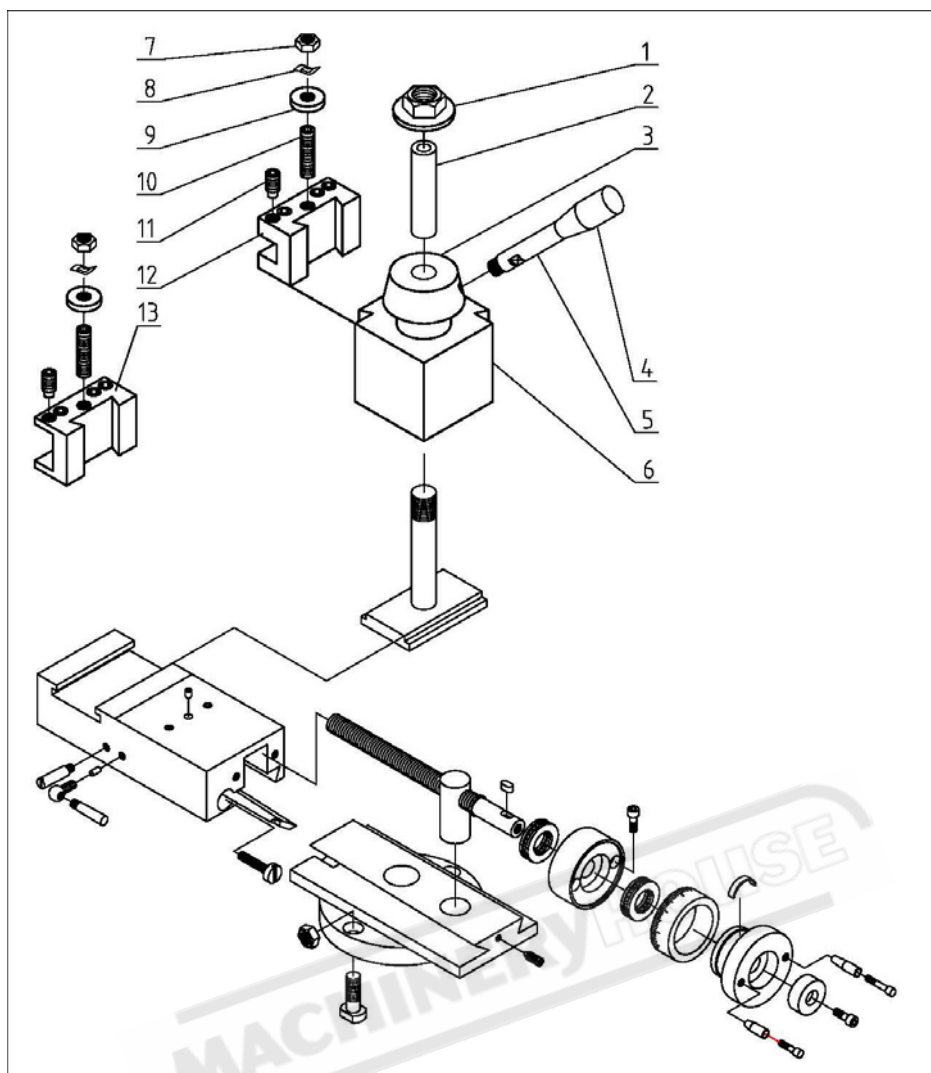
QUICK CHANGE TOOL POST (Optional)

Index No	Part No	Description	Size	Qty
1		Flange nut	M16-2	1
2		Shaft bushing		
3		Tool post lever hub		
4		Handle		
5		Lever		
6		Body		
7		Hex nut	M10-1	2
8		Wavy wash	10mm	2
9		Flat wash	10mm	2
10		Set screw	M10-1X45	2
11		Set screw	M10-1X20	8
12		Tool holder 16mm		1
13		Tool holder 20mm		1

SADDLE POSITION LOCALIZER (Optional)

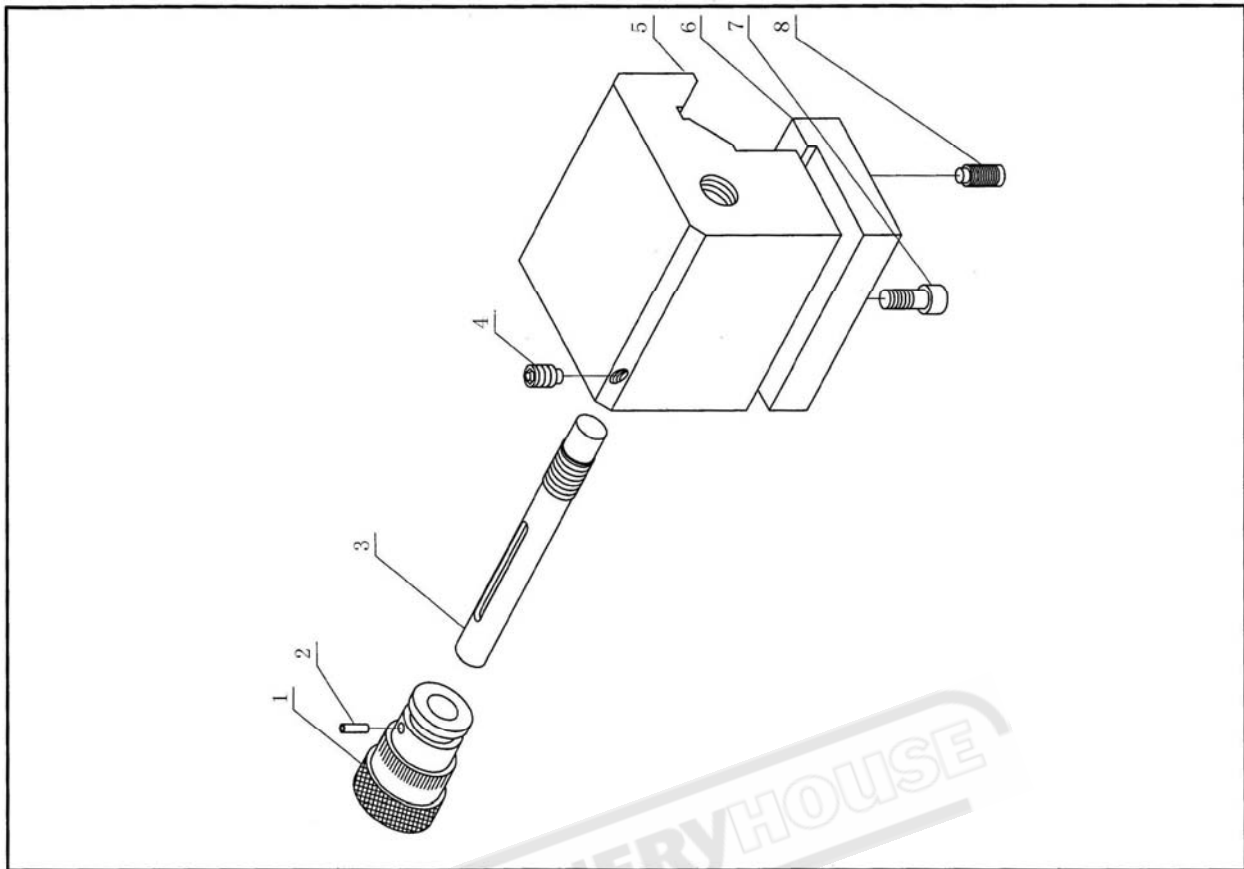

Index No	Part No	Description	Size	Qty
1	D330A-DC003	Index ring		1
2	GB/T879-3X6	Pin	3X6	1
3	D330A-DC004	Shaft		1
4	GB/T79-M6X10	Screw	M6X10	1
5	D330A-DC001	Casting body		1
6	D330A-DC002	Plate		1
7	GB/T70-M6X10	Hex Socket Cap Screw	M6X10	2
8	GB/T79-M5X12	Screw	M5X12	2